

## Compression Posts

The USG **Donn**® Brand Compression Post provides rigid support for a ceiling suspension system in seismic applications. Telescoping compression posts attach to the main tees at each splayed wire location, preventing upward movement of the system, often required by code. Because codes continue to evolve, check with a local official prior to designing and installing a ceiling system.

Available in four different sizes to meet installation requirements, the **Donn** Brand Compression Post is a unique, factory engineered solution that meets the compression requirements for seismic ceiling installations. The variety of factory-sized compression posts with instant length-lock feature saves installation time for overall cost savings.

### Features

- Factory-engineered solution provides system rigidity in seismic applications and offers quick installation reducing field labor time.
- Availability of six different telescoping sizes meets requirements with fast delivery.

Item No.	Size
VSA 18/30	18" to 30"
VSA 30/48	30" to 48"
VSA 48/84	48" to 84"
VSA 84/102	84" to 102"
VSA 102/120	102" to 120"
VSA 120/144	120" to 144"

- Injection-molded, high-impact clip snaps onto the bulb of the main tee for secure, positive locating.
- Heavy-wall galvanized steel tubing, no-rust telescoping post locks into permanent support length.
- Injection-molded guide ring prevents rattling.
- Spring steel top clip for attachment to vertical hanger wire adjacent to post
- The adjustable self-locking connection has been tested and certified to a minimum compressive load of 900 lb.
- Meets UL797

### Components

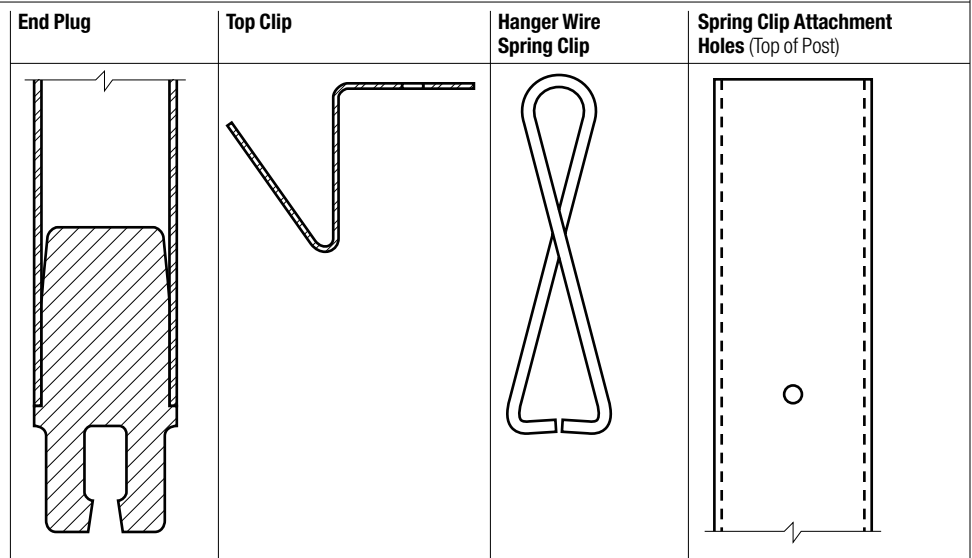

**Note:** All components are included with each post

**Application**

- Step 1** Fit top clip into the opening of the post.
- Step 2** Snap compression post onto main tee bulb next to vertical hanger wire.
- Step 3** Bring compression post to vertical with hanger and extend post for snug fit against structure.
- Step 4** Loop spring clip around vertical hanger wire and connect to holes on top of post.
- Step 5** Mechanically fasten end plug of post to main tee bulb.
- Step 6** Fasten compression post to structure with the appropriate mechanical fastener.

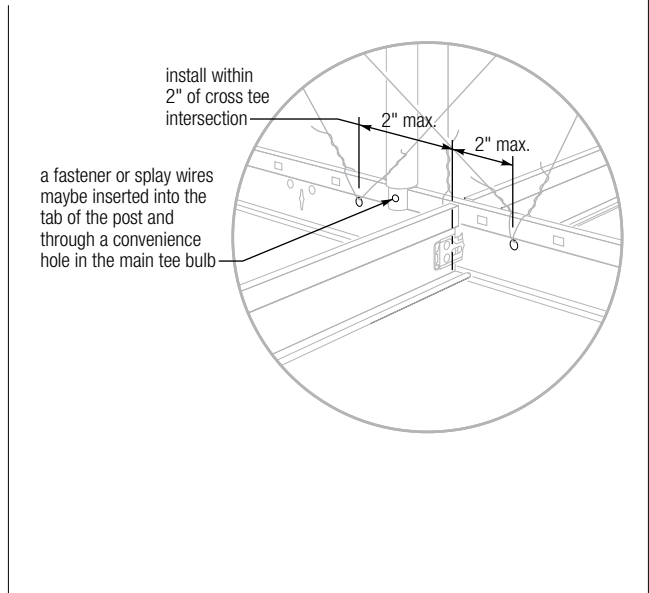
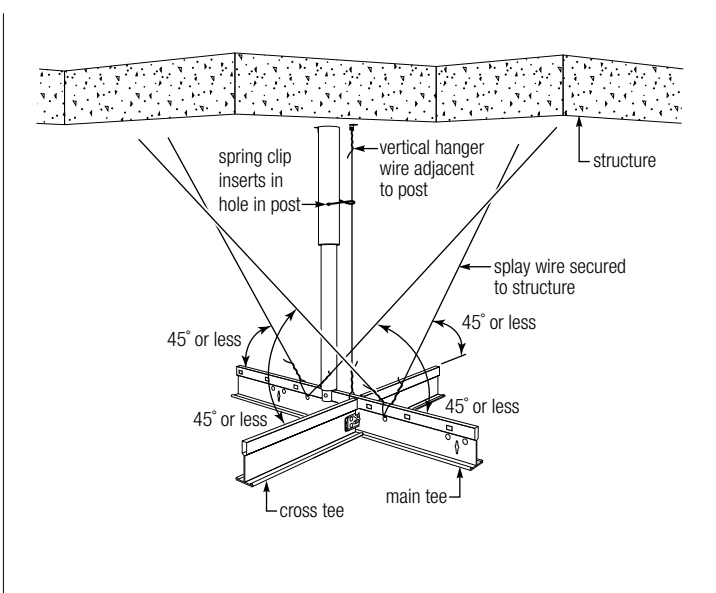
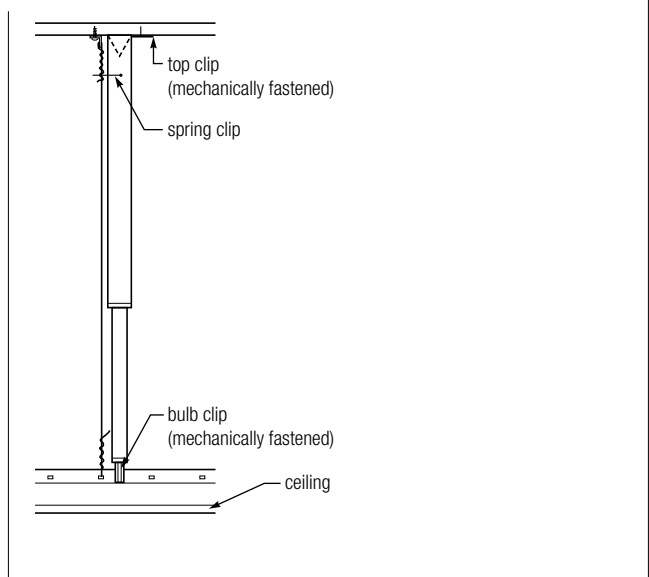
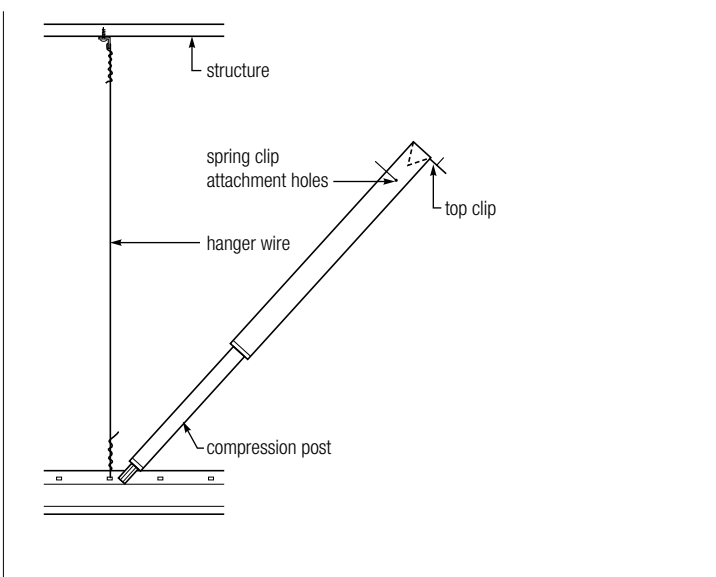

**Alternative Materials**

The USG DOWN Brand compression post is an engineered solution designed to work with USG DOWN Brand Suspension Systems when required by code. The USG DOWN Brand compression post is an option for almost every project, however it is not necessary to use the USG DOWN Brand compression post when installing USG DOWN Brand Suspension Systems. Any steel member with sufficient strength is allowed by code and may be suitable for use as a compression post. Below are some common, light gauge steel members provided by others that are typically used as alternates for compression posts and their typical associated allowable lengths.

<b>Alternate Material</b>	<b>Typical Allowable Length</b>
3/4" x 1/2" x 0.059" Channel	26"
(2) 3/4" x 1/2" x 0.059" Channel, Back to Back	39"
1-1/2" x 9/16" x 0.059" Channel	33"
(2) 1-1/2" x 9/16" x 0.059" Channel, Back to Back	44"
1-5/8" x 1-1/4" x 0.0197" Channel	106"
(2) 1-5/8" x 1-1/4" x 0.0197" Channel, Back to Back	141"
1/2" Diameter EMT Conduit, 0.042" Wall Thickness	47"
3/4" Diameter EMT Conduit, 0.049" Wall Thickness	61"
1" Diameter EMT Conduit, 0.057" Wall Thickness	78"
1-1/4" Diameter EMT Conduit, 0.065" Wall Thickness	102"
1-1/2" Diameter EMT Conduit, 0.065" Wall Thickness	118"
3-5/8" 20GA C-Stud (33KSI)	144"
3-5/8" 18GA C-Stud (33KSI)	168"
3-5/8" 16GA C-Stud (33KSI)	168"
2" Diameter EMT Conduit, 0.065" Wall Thickness	150"

**Notes**

1. The information provided is for quick reference only. Other restrictions and exemptions may apply.
2. All struts and allowable lengths should be verified by a design professional before use.
3. Wind loads may exceed seismic loads. The distances above may not be suitable for exterior use.
4. Wall molding should not be used as struts.
5. A structural engineer should be consulted for lengths greater than 14ft.

---

**Code Compliance**

- ICC-ESR-1222
- City of Los Angeles Research Report: RR25764
- CA Division of the State Architect (DSA) IR-A5 Interpretation of Regulations Manual through reference to ICC-ESR-1222 or CA Division of the State Architect (DSA) IR-A6 Change Order and Field Change Approval Processes.
- CA Office of Statewide Health Planning and Development (OSHPD) please refer to Code Application Notice 2-1708A.5, pre-approval through ICC-ESR-1222 is recommended.

**Product Information**

See usg.com for the most up-to-date product information.

**Installation**

Must be installed in compliance with ASTM C636, ASTM E580, C15CA, and standard industry practices.

**Code Compliance**

The information presented is correct to the best of our knowledge at the date of issuance. Because codes continue to evolve, check with a local official prior to designing and installing a ceiling system. Other restrictions and exemptions may apply. This is only intended as a quick reference.

**ICC Evaluation Service, Inc., Report Compliance**

Suspension systems manufactured by USG Interiors, Inc., have been reviewed and are approved by listing in ICC-ES Evaluation Report ESR-1222. Evaluation Reports are subject to reexamination, revision and possible cancellation. Please refer to usgdesignstudio.com or usg.com for current reports.

**L.A. Research Report Compliance**

Down brand suspension systems manufactured by USG Interiors, Inc., have been reviewed and are approved by listing in the following L.A. Research Report number: 25764.

**Notice**

We shall not be liable for incidental and consequential damages, directly or indirectly sustained, nor for any loss caused by application of these goods not in accordance with current printed instructions or for other than the intended use. Our liability is expressly limited to replacement of defective goods. Any claim shall be deemed waived unless made in writing to us within thirty (30) days from date it was or reasonably should have been discovered.

**Safety First!**

Follow good safety/industrial hygiene practices during installation. Wear appropriate personal protective equipment. Read MSDS and literature before specification and installation.

