

Performance-engineered exterior
substrates that address the
demands of different conditions

USG

Exterior Substrate

Systems

USG exterior system substrates are high-quality sheathing products for exteriors that can be used in a wide variety of applications, including residential, commercial and institutional buildings. They offer a variety of benefits, including wind resistance, fire resistance and water durability, and are designed to integrate with a variety of exterior finish systems, such as brick veneer, EIFS (Exterior Insulated Finish Systems), wood cladding, ceramic tile and marble.

Different substrates perform different functions. For example, very dry regions of the country require less water durability in an exterior substrate than areas that receive a high average rainfall. Areas prone to hurricanes and tropical storms require an exterior substrate that provides greater wind resistance.



Building Solutions

User's Guide

This brochure explains:

- The difference between exterior insulated, direct-applied, and conventional finish systems
- The benefits of using the different types of systems
- The USG products that can be used in a variety of buildings and applications

	Pages	
Understand Your System	4	Overview Applications Components Performance Testing
Select Your System	14	Performance Selector
Design Your System	19	Design Details Good Design Practices
Specify Your System	25	Application Guide Specifications
For More Information		Technical Service 800 USG.4YOU Web Site www.usg.com

Overview

USG exterior system substrates can be used in a variety of external applications, including walls, external soffits, exterior column cladding, and pressure equalized rain screen systems.

There are three general types of exterior finish systems:

- 1 Exterior Insulated Finish Systems (EIFS)
- 2 Direct-Applied Exterior Finish Systems (DEFS)
- 3 Conventional Finish Systems

Exterior insulated systems contain an exterior insulation board, offering superior thermal protection and crack resistance while providing unique design options. Insulated systems can be used in all-weather conditions when water-managed details are incorporated to allow incidental water to escape.

Direct-applied finish systems provide a hard, impact-resistant, economical water-managed alternative, with the added advantage that some designs permit the use of adhered veneers to enhance aesthetics.

Conventional finish systems provide strength and durability in applications where long-term performance is critical.

Applications

Exterior Insulated Finish Systems

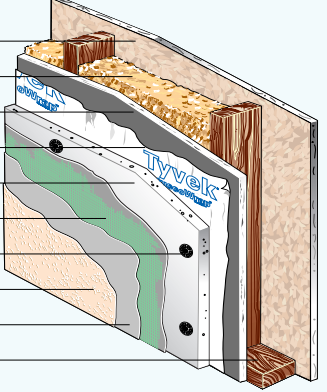
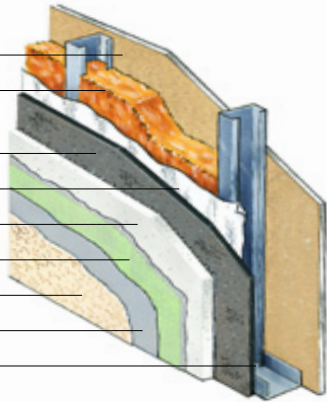
EIFS	Benefits	System Use
<p>Mechanically Attached</p>  <p>SHEETROCK Brand gypsum panel</p> <p>cavity insulation (optional)</p> <p>FIBEROCK Brand AQUA-TOUGH sheathing</p> <p>TYVEK STUCCOWRAP weather-resistant barrier</p> <p>insulation board</p> <p>mesh reinforcement</p> <p>mechanical fastener</p> <p>textured finish</p> <p>basecoat</p> <p>framing</p>	<ul style="list-style-type: none"> – High-performance TYVEK® STUCCOWRAP® Weather-Resistant Barrier protects system and helps drain water – With water barrier, flashing and proper details, provides an economical, water-managed, energy-efficient system – Designed for use with FIBEROCK® Brand AQUA-TOUGH™ Sheathing, DUROCK® Brand Cement Board or SHEETROCK® Brand Gypsum Sheathing 	<p>A mechanically attached EIFS uses mechanical fasteners to hold the insulation board in place. Because the mechanical fasteners attach the entire system directly into the framing, it provides better drainage than an adhesively attached system.</p>
<p>Adhesively Attached</p>  <p>SHEETROCK Brand gypsum panel</p> <p>cavity insulation</p> <p>FIBEROCK Brand AQUA-TOUGH sheathing or DUROCK Brand cement board</p> <p>TYVEK STUCCOWRAP weather-resistant barrier</p> <p>insulation board</p> <p>mesh reinforcement</p> <p>textured finish</p> <p>basecoat</p> <p>framing</p>	<ul style="list-style-type: none"> – Designed for use with FIBEROCK Brand AQUA-TOUGH Sheathing or DUROCK Brand Cement Board Sheathing – Offers superior aesthetics of an adhesive-only bonded system – Ideal for applications where long-term performance is critical – Stands up to harsh climates, including wind and humidity 	<p>An adhesively attached EIFS uses an adhesive to hold each layer of the system to the next. It is typically not as drainable as mechanically attached systems, but it is cheaper to construct. Adhesively attached systems are often used in projects where a uniform surface and a smoother, flatter appearance are required.</p>

Applications

Direct-Applied Exterior Finish Systems

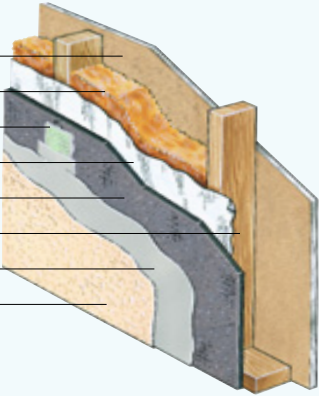
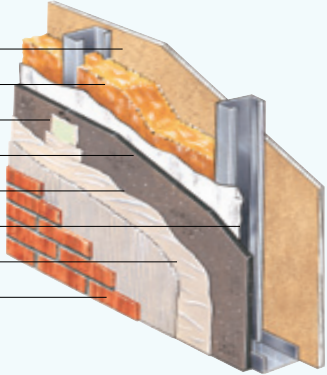
DEFS	Benefits	System Use
<p>Textured Acrylic Finish</p>  <p>SHEETROCK Brand gypsum panel cavity insulation DUROCK Brand exterior joint tape TYVEK STUCCOWRAP weather-resistant barrier DUROCK Brand cement board framing basecoat textured finish</p>	<ul style="list-style-type: none"> – Provides a long-lasting, durable, puncture-resistant substrate – Withstands high temperature, humidity, water, wind and repeated freeze-thaw cycles – Compatible with exterior finish systems – Recognized by building codes – Can be installed in as little as two days, speeding occupancy 	<p>Acrylic finishes feature elongation properties that help prevent cracking. Because they are more impact-resistant, they can withstand extreme temperature fluctuations.</p>
<p>Thin-Set Adhered Veneer</p>  <p>SHEETROCK Brand gypsum panel cavity insulation DUROCK Brand exterior joint tape TYVEK STUCCOWRAP weather-resistant barrier DUROCK Brand cement board framing latex-modified portland cement mortar thin brick or ceramic tile</p>	<ul style="list-style-type: none"> – May be finished with ceramic tile and thin brick, or any combination of these finishes with stucco-look finishes – Incorporates the durability of DUROCK Brand Cement Board – Meets the requirements of the Ceramic Tile Institute, and is included in its Tested Materials List 	<p>Thin-set latex-modified portland cement mortars are similar to basecoats used on EIFS applications. They are used to adhere tile, thin brick, or other finishes to a water- and weather-durable substrate.</p>

Conventional Finish Systems

		Benefits	System Use
Conventional Stucco			
<p>SHEETROCK Brand gypsum panel</p> <p>cavity insulation</p> <p>FIBEROCK Brand AQUA-TOUGH sheathing</p> <p>TYVEK STUCCOWRAP weather-resistant barrier</p> <p>metal lath</p> <p>framing</p> <p>exterior stucco</p>		<ul style="list-style-type: none"> – Economical ways to construct conventional stucco systems – Provides strength and durability for portland cement stucco – Designed for use with FIBEROCK Brand AQUA-TOUGH Sheathing, DUROCK Brand Cement Board or SHEETROCK Brand Gypsum Sheathing 	<p>Portland cement, sand and lime mixture that provides high impact resistance, water-permeable exterior surface, and a variety of colors and textures. It can be applied directly to a solid base such as concrete walls or masonry, or can be applied to metal lath over sheathing attached to the frame.</p>
Conventional Brick Veneer			
<p>SHEETROCK Brand gypsum panel</p> <p>cavity insulation</p> <p>framing</p> <p>brick tie</p> <p>FIBEROCK Brand AQUA-TOUGH sheathing</p> <p>TYVEK STUCCOWRAP weather-resistant barrier</p> <p>brick veneer</p> <p>1" air space</p> <p>weep</p> <p>asphaltic, rubber or metal flashing</p> <p>brick ledge at foundation</p>		<ul style="list-style-type: none"> – Employs high-performance fiber-reinforced FIBEROCK Brand AQUA-TOUGH Sheathing, SHEETROCK Brand Gypsum Sheathing or DUROCK Brand Cement Board – Ideal for applications where long-term performance is critical – Stands up to harsh climates, including wind and humidity 	<p>A single width of brick that is tied to sheathed wood or steel framing with metal ties. This type of system is used in both residential and commercial building construction to achieve the look and durability of brick without the added weight of a solid masonry design.</p>
Pressure Equalized Rain Screen			
<p>SHEETROCK Brand gypsum panel</p> <p>cavity insulation</p> <p>framing</p> <p>brick tie</p> <p>FIBEROCK Brand AQUA-TOUGH sheathing</p> <p>TYVEK STUCCOWRAP weather-resistant barrier</p> <p>brick veneer</p> <p>pressure equalized cavity</p> <p>protected vent (top)/weep (bottom)</p> <p>asphaltic, rubber or metal flashing</p> <p>brick ledge at foundation</p>		<ul style="list-style-type: none"> – Uses FIBEROCK Brand AQUA-TOUGH Sheathing, SHEETROCK Brand Gypsum Sheathing or DUROCK Brand Sheathing – Minimizes infiltration of water into exterior wall – Provides pressure equalization across exterior cladding and adjacent air cavity – Minimizes infiltration of water into exterior wall 	<p>Air pressure is a major cause of water intrusion. The principle behind a pressure equalized rain screen is that the rain screen or exterior cladding contains protected openings to facilitate the passage of air, but not water. The air pressure of the air cavity behind the rain screen is then essentially the same as the external air pressure.</p>

Components

Substitutions of any of the components are not recommended and are not supported by the United States Gypsum Company. Refer to the appropriate product material safety data sheet for complete health and safety information.

Substrates

DUROCK Brand Cement Board

- Aggregated portland cement board with polymer-coated, glass fiber mesh embedded in back and front surfaces.
- Ends are square cut and edges are reinforced and finished smooth
- Provides a superior base for textured finish, thin brick, ceramic tile, adhesively attached or “water-managed” EIFS
- 10-year limited labor and materials warranty
- Refer to product submittal sheet CB399 for complete information

FIBEROCK Brand AQUA-TOUGH Sheathing

- Unique engineered drainage design on back surface
- Outperforms paper- or glass-mat-faced gypsum sheathing
- Strong and water-durable, with a unique water-drainage capability
- With no face paper or mesh, more reliable as a substrate for adhesively attached and water-managed EIFS
- 10-year limited warranty, 12-month exposure warranty
- Refer to product submittal sheet F135 for complete information

SHEETROCK Brand Gypsum Sheathing

- Fire-resistant treated core encased in water-repellent paper on both sides and long edges
- Ideal for use in exterior steel- or wood-framed construction on single-family housing, apartments, motels and light commercial buildings
- With conventional exterior stucco, sheathing provides flatter walls, and a more uniform plaster thickness
- For use in mechanically attached, water-managed EIFS systems that require a water barrier applied over the sheathing
- Also available in 5/8” FIRECODE® Core
- Refer to product submittal sheet GS116 for complete information

Substrate Selector

Product	DUROCK Brand Cement Board	FIBEROCK Brand AQUA-TOUGH Sheathing	SHEETROCK Brand Gypsum Sheathing
Direct-Applied Finish Systems			
Acrylic Finish System	•		
Thin-Set System (brick, stone, tile)	•		
Conventional Finish Systems			
Conventional Stucco	•	•	•
Conventional Brick Veneer and Stone	•	•	•
Rain Screen System	•	•	
Exterior Insulated Finish Systems			
Mechanically Attached EIFS	•	•	•
Adhesively Attached EIFS	•	•	
Exterior Soffit Systems			
Exterior Soffit Adhesively Attached Insulation	•	•	
Exterior Soffit—Textured Finish	•	•	
Exterior Soffit—Smooth Finish	•	• ^a	

Related Products

DUROCK Brand Exterior Joint Tape

- Alkali-resistant glass-fiber construction is specially designed to reinforce joints and corners of DUROCK Brand Cement Board, or where panels of other materials, such as gypsum panels, abut cement boards
- Refer to product submittal sheet ES338 for complete information

DUROCK Brand and USG Sheathing Screws for Wood and Steel Framing

- Wafer-head design provides greater holding power
- Special coating provides corrosion resistance
- Ideal for attachment of cement board
- Refer to product submittal sheets CB400 and ES339 for complete information

TYVEK® STUCCOWRAP™ Weather-Resistant Barrier

- Spunbonded olefin material developed by DuPont Company with assistance from the United States Gypsum Company is engineered to improve the effectiveness of USG exterior substrates that require a weather-resistive barrier
- Features include engineered surface design, superior water resistance, high permeance value, excellent tear resistance, and pliability in a lightweight product

SHEETROCK Brand DURABOND® Setting Type Joint Compound

- General purpose, chemically hardening (setting-type) compound that permits quick finishing
- Ideal for heavy fills and for patching
- Setting rates are virtually unaffected by humidity
- Refer to product submittal sheet J17A for more information

Note

(a) FIBEROCK Brand AQUA-TOUGH Interior Panel can be used in an exterior soffit when a smooth surface and tapered edge are required.

Performance Testing

Exterior wall sheathing provides weather resistance, durability and strength to frame construction. While wood or steel framing can stand on its own without sheathing, the frame cannot provide proper support to the wall finish or protect the building against fire, moisture intrusion, and air filtration without a properly applied sheathing.

USG exterior substrates provide fire and moisture resistance, stay flat, and resist swelling. The panels can transfer wind load to the framing without breaking or deforming beyond an acceptable limit. When properly fastened, they will stay secured to the wall for the service life of the building under both positive and negative wind loads.

Performance Tests

USG's exterior substrates result from a program of extensive testing and continuous improvements, backed by over 100 years of experience in the building materials industry. This extensive testing ensures the superior strength performance that your project demands.

Testing Methods

All USG products and systems undergo exhaustive testing to ensure that they meet exacting standards. USG's products are Classified as to fire resistance and fire-hazard properties. As part of this protocol, UL periodically audits production of these materials to ensure compliance with necessary properties. UL is an independent, not-for-profit product safety testing and certification organization that has tested products for public safety for over a century.

Products are manufactured and tested in accordance with ASTM standards. ASTM International is one of the largest voluntary standards development organizations in the world, and is a trusted source for technical standards for materials, products, systems, and services.

Testing Results

Fire Protection

In the event of a fire, it is critically important to the safety of occupants that exterior substrate materials are fire-resistant. Testing results ensure that this critical performance of the assembly will not be compromised when materials are properly installed.

This fire testing results in the following:

- UL Classification of all three substrate materials
- UL listing of system fire-resistance ratings for 1-2 hours

See the Performance Selector in this brochure for more information on fire resistance.

Testing Results

Water Durability

The best way to minimize damage from moisture, mold and mildew is to minimize or eliminate exposure to water before, during and after construction. In all cases where moisture intrusion occurs, eliminate all sources of moisture immediately. The building must be designed to provide proper control of condensation to avoid trapping water within building assemblies.

During construction, sheathings are used to enclose buildings, permitting interior work to continue regardless of weather conditions. Sheathings that can withstand direct exposure to weather for longer periods permit greater flexibility in construction scheduling. Water resistance also plays a key role in long-term exterior wall performance.

It is important to match the sheathing selection with local climate conditions. Depending on the exterior finish, both DUROCK Brand Cement Board and FIBEROCK Brand AQUA-TOUGH Sheathing are appropriate for wet climates such as coastal areas and regions with moderate to heavy rainfall, especially those areas with average rainfall exceeding 20 inches. Use DUROCK Brand Cement Board for EIFS and ceramic tile finishes, and FIBEROCK Brand AQUA-TOUGH Sheathing for EIFS and brick veneer. For more moderate moisture conditions, SHEETROCK Brand Gypsum Sheathing offers integral water resistance.

Resistance to Mold	DUROCK Brand Cement Board	FIBEROCK Brand AQUA-TOUGH Sheathing
ASTM D3273 ^a	10	10

Note

(a) ASTM D3273—Standard Test Method for Resistance to Growth of Mold on the Surface of Interior Coatings in an Environmental Chamber. A '0' rating means excessive disfigurement due to mold growth, while a '10' rating indicates that no mold grew.

Performance Testing

Testing Results

Sustainability

The LEED® (Leadership in Energy and Environmental Design) program is a guideline for building solutions established by the U.S. Green Building Council (USGBC). LEED's mission is to transform the building industry by establishing a common standard of measurement to define what constitutes a "green building." To this end, LEED provides a framework for assessing building performance and meeting sustainability goals. This framework assigns points for certain sustainability criteria, such as sustainable site development, water savings, energy efficiency, materials selection and indoor environmental quality.

Specific products cannot be LEED-certified, because there are many contingent factors in each project that must be considered. However, certain products may assist you in obtaining LEED points for your design solution. For example:

USGBC LEED Credits	MR 2	
Construction Waste Management	2.1	Divert 50% of project waste (by weight) from landfill (1 point)
	2.2	Divert another 25% of project waste (by weight) from landfill (1 point)
Recycled Content	MR 4	
	4.1	If 25% of project materials by weight have 20% post-consumer or 40% post-industrial (1 point)
	4.2	Another 25% of project materials (1 point)
Local/Regional Materials	MR 5	
	5.1	If 20% of project materials are manufactured within 500 miles (1 point)
	5.2	If raw materials for above products are obtained within 500 miles of manufacturing (1 point)
Low-Emitting Materials	EQ 4	
	4.2	Drywall installation less than 200g/L per Green Seal, Table 5 (1 point)

The following chart lists the USG exterior substrates that may be eligible for LEED points. But using products with a high recycled content is only one part of the equation. Another key measure of sustainability is embodied energy, which assesses the total energy required to produce a particular material or building component and get it to a building site. For example, if you use a product with a high recycled content but need to ship it across the country, the embodied energy costs of transportation may outweigh any environmental advantages of using a recycled product. It may be more environmentally sound to ship natural gypsum wallboard products from a plant close to a job site.

USGBC LEED Credits	MR 4.1 and 4.2				EQ 4	MR 5.2	
Product Family	Post-Consumer	Post-Industrial	Embodied Energy ^{a,b}	Density lbs./cu. ft.	VOC ^c	Mfg. Efficiency	Raw Materials (% by weight)
SHEETROCK Brand Gypsum Panels—percent varies across 23 plants nationwide ^d	~5%	0%-95% 36.5% average	3.6 MJ/kg	43-50	None	95%+	95% gypsum, 5% paper, 1% starch; special panel with wax and glass fiber
DUROCK Brand Cement Board	0	20%	10 MJ/kg	72			Portland cement and fly ash
FIBEROCK Brand Panels ^d	10%	85%	5 MJ/kg	55	None	95%	85% FGD gypsum (barged 250 miles), 10% cellulose (local), and 1% starch (local)

Notes

(a) Megajoules per kilogram. (b) Transportation of gypsum board accounts for over 10% of the board's embodied energy, while mining accounts for less than 1%. (c) Section 01350 of the Material Specifications adopted by the Collaborative for High Performance Schools (CHPS) for VOC emissions. (d) USG uses more recaptured (FGD or flue gas desulfurization) gypsum than any other wallboard supplier—over 3 million tons in 2003. Based on current operations, all FIBEROCK Brand panels use FGD gypsum, but the FGD gypsum content of SHEETROCK Brand panels changes from plant to plant and even day to day at any one plant, due to availability. The recycled contents above are approximate, based on plant averages for 2002. Most of the power plants that produce recaptured gypsum are east of the Mississippi River. While FGD gypsum is not available everywhere in North America, USG does have plants strategically located to meet your needs. Evaluation should be made for each job on the benefits of using FGD instead of natural gypsum.

Technical Data

Physical Properties for 1/2" Thickness Sheathing

Property	ASTM Test Reference	DUROCK Brand Cement Board	FIBEROCK Brand AQUA-TOUGH Sheathing	SHEETROCK Brand Gypsum Sheathing
Flexural Strength				
– Bearing edge perpendicular to board length—psi	C947-81	750	840	770
– Bearing edge parallel to board length—psi	C947-81	750	840	280
Water Absorption—% by wt. 2 hrs	C473-84	10	5	10
Nail Pull Resistance (0.4" head diameter)—lb.	C473-84	125	120	80
Weight—psf (1/2" thick)	C473-84	3	2.2	1.9
Surface Burning Characteristics—flame/smoke	E84-84	5/0	5/0	15/0

Typical Thermal Properties

Product	Thickness (in.)	"C"	"R"
SHEETROCK Brand Gypsum Sheathing	1/2	2.22	0.45
SHEETROCK Brand Gypsum Sheathing	5/8	1.79	0.56
FIBEROCK Brand AQUA-TOUGH Sheathing	1/2	3.33	0.30
FIBEROCK Brand AQUA-TOUGH Sheathing	5/8	2.66	0.38
DUROCK Brand Cement Board	1/2	3.85	0.26
DUROCK Brand Cement Board	5/8	3.12	0.32

Wind Load Design Table

Product	Wall Height	Stud Spacing	Design Wind Load ^{a,b,c,d,e}			
			20 psf	30 psf	40 psf	50 psf
DUROCK Brand Cement Board	10'	12" o.c.	Stud: 350S162-33	Stud: 350S162-33	Stud: 400S162-33	Stud: 550S162-33
			Panel: 1/2" DUROCK	Panel: 1/2" DUROCK	Panel: 1/2" DUROCK	Panel: 1/2" DUROCK
			Fasteners: 8" o.c.	Fasteners: 8" o.c.	Fasteners: 8" o.c.	Fasteners: 8" o.c.
		16" o.c.	Stud: 350S162-33	Stud: 400S162-33	Stud: 560S162-33	Stud: 550S162-33
			Panel: 1/2" DUROCK	Panel: 1/2" DUROCK	Panel: 1/2" DUROCK	Panel: 5/8" DUROCK
			Fasteners: 8" o.c.	Fasteners: 8" o.c.	Fasteners: 8" o.c.	Fasteners: 6" o.c.
FIBEROCK AQUA-TOUGH Brand Sheathing	10'	12" o.c.	Stud: 350S162-33	Stud: 350S162-33	Stud: 400S162-33	Stud: 550S162-33
			Panel: 1/2" FIBEROCK	Panel: 1/2" FIBEROCK	Panel: 1/2" FIBEROCK	Panel: 1/2" FIBEROCK
			Fasteners: 12" o.c.	Fasteners: 12" o.c.	Fasteners: 12" o.c.	Fasteners: 12" o.c.
		16" o.c.	Stud: 350S162-33	Stud: 400S162-33	Stud: 550S162-33	Stud: 550S162-33
			Panel: 1/2" FIBEROCK	Panel: 1/2" FIBEROCK	Panel: 1/2" FIBEROCK	Panel: 1/2" FIBEROCK
			Fasteners: 12" o.c.	Fasteners: 12" o.c.	Fasteners: 12" o.c.	Fasteners: 8" o.c.
		24" o.c.	Stud: 400S162-33	Stud: 550S162-33	Stud: 550S162-33	Stud: 600S162-33
			Panel: 1/2" FIBEROCK	Panel: 5/8" FIBEROCK	Panel: 2 layers 1/2" FIBEROCK	Panel: 2 layers 1/2" FIBEROCK
			Fasteners: 12" o.c.	Fasteners: 12" o.c.	Fasteners: 8" o.c.	Fasteners: 6" o.c.

Allowable Wind Loading

Product	Stud Type	Stud Spacing (in.)	Insulation Board Type	Fastener Spacing (in.)	Typical Allowable Load (psf) ^{f,g,h}
Mechanically Attached Insulation Board	Wood	16	exp. polystyrene (EPS)	8	30
	Steel (20 ga. min.)	16	exp. polystyrene (EPS)	8	25

Notes

(a) Stud sizes are based on Steel Stud Manufacturers Assoc. Product Technical Information and assume sheathing or wallboard on each flange of stud. Maximum allowable deflection is L/240 wall height. Stud designation is xx8y-zz, where xx = depth in 1/100 inches, yy = flange width in 1/100 inches, zz = steel thickness in 1/1000 inches. Members up to 8" deep were sized assuming 1-5/8" flange width and 20 gauge (0.033") steel thickness only. Shallower studs may be used if steel gauge is increased accordingly—consult SSMA design tables for guidance. (b) Panel size and fastener spacing is based on a factor of safety = 3 applied to published flexural strength and nail pull capacities for DUROCK Brand Cement Board and FIBEROCK Brand panels. (c) Design is based on structural considerations only. Other design considerations (e.g., fire-rated construction) may dictate stricter requirements. (d) The panels are not required to be laminated together, where double layer of panels is shown. (e) See your USG Sales Representative for wall heights not listed. (f) Allowable loads based on board and fastener failure modes only. Design of framing is the responsibility of the architect or engineer of record. (g) For wind loads beyond this table, consult with the EIFS manufacturer. (h) Maximum positive or negative wind load.

Performance Selector

Exterior Walls

Steel Framed



1 Hour Fire-rated Construction		Non-loadbearing	Acoustical Performance		Reference	
Construction Detail	Description	Test Number	STC	Test Number	ARL	Index
	<ul style="list-style-type: none"> • 5/8" SHEETROCK Brand FIRECODE Core Gypsum Sheathing or FIBEROCK Brand AQUA-TOUGH Exterior Sheathing, exterior side – 3-1/2" 20 gauge structural studs 24" o.c. • 5/8" SHEETROCK Brand FIRECODE Core Gypsum Panels, interior side <p>– loadbearing up to 100% allowable stud axial load</p>	UL Des U419		Rating also applies with SHEETROCK Brand Water-Resistant FIRECODE Core Gypsum Panels, exterior	SA700	1
	<ul style="list-style-type: none"> • 1/2" SHEETROCK Brand Gypsum Sheathing or 5/8" FIBEROCK Brand AQUA-TOUGH Exterior Sheathing – 1" extruded polystyrene insulation installed horizontally – 3-1/2" 20 gauge structural studs 24" o.c. – 1/2" cedar plywood exterior – 3-1/2" insulating blankets between studs • 5/8" SHEETROCK Brand FIRECODE C Core Gypsum Panels, interior side – joints finished 	CEG 12-7-79			SA700	2
	<ul style="list-style-type: none"> • 1/2" DUROCK Brand Cement Board and 1/4" ceramic tile exterior side – 3-5/8" 20 gauge studs 16" o.c. – 3" THERMAFIBER SAFB • 5/8" SHEETROCK Brand FIRECODE Core Gypsum Panels or FIBEROCK Brand AQUA-TOUGH Interior Panels • optional veneer plaster 	UL Des U442			SA700	3
	<ul style="list-style-type: none"> • 1/2" DUROCK Brand Cement Board exterior side – 3-5/8" 20 gauge steel studs 16" o.c. – 3" THERMAFIBER SAFB • 5/8" SHEETROCK Brand FIRECODE C Core Gypsum Panels, interior side 	UL Des U457			SA700	4
	<ul style="list-style-type: none"> • 1/2" DUROCK Brand Cement Board – 1-5/8" 20 gauge steel studs 16" o.c. – 1-1/2" THERMAFIBER SAFB • 5/8" SHEETROCK Brand FIRECODE C Core Gypsum Panels 	UL Des U458			SA700	5
	<ul style="list-style-type: none"> • 5/8" SHEETROCK Brand FIRECODE Core Gypsum Sheathing or FIBEROCK Brand AQUA-TOUGH Sheathing, exterior side • 5/8" SHEETROCK Brand FIRECODE Core Gypsum Panels, interior – 3-5/8" steel studs 24" o.c. 	UL Des U419, U465			SA700	5
	<ul style="list-style-type: none"> • 5/8" SHEETROCK Brand FIRECODE Core Gypsum Panels or IMPERIAL Brand FIRECODE Core Abuse-Resistant Gypsum Base, or FIBEROCK Brand Panels – 3-5/8" 25 gauge steel studs 24" o.c. – joints finished • optional veneer plaster 	UL Des U419 or U465	40 49 51	USG-860808 SA-870717 Based on 3" SAFB in cavity RAL-TL-90-166 Based on 5/8" FIRECODE C Core panels and 3" SAFB, and veneer finish surface SAFB 25" wide, creased to fit cavity	SA700 SA920	7

Exterior Walls

Steel Framed



2 Hour Fire-rated Construction		Non-loadbearing		Reference	
Construction Detail	Description	Test Number	Comments	ARL	Index
<p>wt. 11</p>	<ul style="list-style-type: none"> • 1/2" DUROCK Brand Cement Board • base layer 1/2" SHEETROCK Brand Water-Resistant FIRECODE C Core Gypsum Panels, both sides – 3-5/8" 20 gauge minimum steel studs 16" o.c. – 3" THERMAFIBER SAFB • alternate design, double-layer 1/2" SHEETROCK Brand FIRECODE C Core Gypsum Panels, interior 	UL Des U474		SA700	8
<p>wt. 12</p>	<ul style="list-style-type: none"> • layer 5/8" SHEETROCK Brand FIRECODE Core Gypsum Sheathing or 5/8" FIBEROCK Brand AQUA-TOUGH Sheathing, exterior side • 5/8" SHEETROCK Brand FIRECODE Core Gypsum Panels, interior side – 2-1/2" studs 24" o.c – joints stag and finished or unfinished 	UL Des U411, U419		SA700	9
	<ul style="list-style-type: none"> • 5/8" SHEETROCK Brand FIRECODE C Core Foil-backed Gypsum Panels – 3-5/8" 20 gauge steel studs 16" o.c. – 1/2" gypsum sheathing – self-furring metal lath – 1" cement-lime stucco exterior side – 3" insulating blankets between studs • optional veneer plaster 	OSU-T-4851	Systems offer wide selection of exterior and interior surfaces, using conventional materials	SA700	10
	<ul style="list-style-type: none"> • 1" SHEETROCK Brand Gypsum Liner Panels or SHEETROCK Brand Enhanced Gypsum Liner Panels – steel C-H studs 24" o.c. • 2 layers SHEETROCK Brand FIRECODE C Core Gypsum Panels or SHEETROCK Brand HUMITEK Gypsum Panels, screw attached on interior – joints finished 	U of C 4-2-75	Rating also applies with IMPERIAL Brand FIRECODE C Core Gypsum Base, and veneer finish interior	SA700	11
<p>wt. 11</p>	<ul style="list-style-type: none"> • 1/2" or 5/8" DUROCK Brand Cement Board – 3-1/2" 20 gauge steel studs 16" o.c. – 3" THERMAFIBER SAFB – joints treated • 5/8" SHEETROCK Brand FIRECODE Core Gypsum Panels, other side 	UL Des U404		SA700	12
<p>wt. 11</p>	<ul style="list-style-type: none"> • 5/8" SHEETROCK Brand FIRECODE Core Gypsum Panels one side • 1/2" or 5/8" DUROCK Brand Cement Board – 3-1/2" 20 gauge steel studs 16" o.c. – 3" THERMAFIBER SAFB • USG Plaster Bonder over Cement Board and treated joints • face layer joints treated with USG setting-type joint compound and paper tape • optional veneer plaster 	UL Des U404		SA920 SA700	13

Performance Selector

Exterior Walls

Steel Framed



45 Minute Fire-rated Construction		Loadbearing	Acoustical Performance		Reference	
Construction Detail	Description	Test Number	STC	Test Number	ARL	Index
wt. 5 	<ul style="list-style-type: none"> • 1/2" SHEETROCK Brand FIRECODE Core Gypsum Sheathing – 3-1/2" 20 gauge structural steel studs 24" o.c. • 1/2" SHEETROCK Brand FIRECODE C Core Gypsum Panels, interior side <p><i>loadbearing up to 100% allowable stud axial load</i></p>	UL Des U423 or U425			SA700	14
1 Hour Fire-rated Construction						
wt. 7 psf 	<ul style="list-style-type: none"> • 1/2" DUROCK Brand Cement Board – 3-1/2" 20 gauge steel studs 16" o.c. – 3" THERMAFIBER SAFB • 5/8" SHEETROCK Brand FIRECODE Core Gypsum Panels or FIBEROCK Brand AQUA-TOUGH Exterior Sheathing, other side 	UL Des U404			SA700	15
wt. 6 	<ul style="list-style-type: none"> • 5/8" SHEETROCK Brand FIRECODE Core Gypsum Panels or FIBEROCK Brand Panels – 3-1/2" 20 gauge steel structural studs 24" o.c. • optional veneer plaster 	UL Des U423 or U425	40 41	USG-810519 USG-810518 Based on 2" mineral wool batt in cavity	SA920 SA700	16
wt. 9 	<ul style="list-style-type: none"> • 1/2" DUROCK Brand Cement Board • base layer 5/8" SHEETROCK Brand Water-Resistant FIRECODE Core Gypsum Panels – 3-1/2" 20 gauge steel load-bearing studs 16" o.c. – 3" THERMAFIBER SAFB • 5/8" SHEETROCK Brand FIRECODE Core Gypsum Panels, interior side 	UL Des U473			SA700	17
1-1/2 Hour Fire-rated Construction						
	<ul style="list-style-type: none"> • 1/2" DUROCK Brand Cement Board • 1/2" SHEETROCK Brand Gypsum Sheathing or 5/8" FIBEROCK Brand AQUA-TOUGH Exterior Sheathing, exterior side – 3-1/2" 20 gauge steel structural studs 24" o.c. • 5/8" SHEETROCK Brand FIRECODE Core Gypsum Panels, interior side <p><i>loadbearing up to 100% allowable stud axial load</i></p>	UL Des U424 or U425		Rating applicable to fire exposure on interior face only	SA700	18
wt. 12 	<ul style="list-style-type: none"> • 1/2" DUROCK Brand Cement Board • base layer 5/8" SHEETROCK Brand FIRECODE Core Gypsum Sheathing or 5/8" FIBEROCK Brand AQUA-TOUGH Exterior Sheathing – 2 x 4 wood studs 16" o.c. – 3" THERMAFIBER SAFB – joints finished • 5/8" SHEETROCK Brand FIRECODE Core Gypsum Panels, other side 	UL Des U308			SA700	19

Exterior Walls

Steel Framed



1-1/2 Hour Fire-rated Construction		Loadbearing	Reference		
Construction Detail	Description	Test Number	Comments	ARL	Index
<p>5 1/2"</p>	<ul style="list-style-type: none"> • 1/2" SHEETROCK Brand FIRECODE Core Gypsum Sheathing or FIBEROCK Brand AQUA-TOUGH Exterior Sheathing, exterior side – 3-1/2" 20 gauge structural studs 24" o.c. • 1/2" SHEETROCK Brand FIRECODE Core Gypsum Panels, interior side <p><i>loadbearing up to 100% allowable stud axial load</i></p>	UL Des U423 or U425		SA700	20
2 Hour Fire-rated Construction					
<p>wt. 11</p> <p>5 3/4" 6"</p>	<ul style="list-style-type: none"> • 1/2" DUROCK Brand Cement Board – 3-1/2" 20 gauge steel studs 16" o.c. – 3" THERMAFIBER SAFB – joints finished • 5/8" SHEETROCK Brand FIRECODE Core Gypsum Panels or FIBEROCK Brand AQUA-TOUGH Exterior Sheathing, other side 	UL Des U404		SA700	21
<p>wt. 12</p> <p>6"</p>	<ul style="list-style-type: none"> • 5/8" SHEETROCK Brand FIRECODE Core Gypsum Sheathing or FIBEROCK Brand AQUA-TOUGH Sheathing, exterior side – 3-1/2" 20 gauge structural steel studs 24" o.c. • 5/8" SHEETROCK Brand FIRECODE Core Gypsum Gypsum Panels, interior <p><i>loadbearing up to 100% allowable stud axial load when min. 2" THERMAFIBER mineral wool batt is used in stud cavities; otherwise load-bearing up 80% allowable steel axial load</i></p>	UL Des U423 or U425	Rating also applies with SHEETROCK Brand FIRECODE Core Water-Resistant Gypsum Panels	SA700	22

Performance Selector

Exterior Walls

Wood Framed



1 Hour Fire-rated Construction		Loadbearing	Reference		
Construction Detail	Description	Test Number	Comments	ARL	Index
wt. 9 psf 	<ul style="list-style-type: none"> • 1/2" DUROCK Brand Cement Board, interior side – 15/32" plywood – 2 x 4 wood studs 16" o.c. – 3" THERMAFIBER SAFB – joints finished • 5/8" SHEETROCK Brand FIRECODE Core Gypsum Panels or FIBEROCK Brand AQUA-TOUGH Exterior Sheathing, other side 	UL Des U303		SA700	23
	<ul style="list-style-type: none"> • 5/8" SHEETROCK Brand FIRECODE C Core Gypsum Panels, interior side – 2x4 16" wood studs o.c. – 3-1/2" THERMAFIBER SAFB – 1" extruded polystyrene insulating sheathing and 1/2" plywood siding – joints finished 	UL Des U330		SA700	24
wt. 15 	<ul style="list-style-type: none"> • 1/2" DUROCK Brand Cement Board and 1/4" ceramic tile exterior – 2 x 4 wood studs 16" o.c. – 3-1/2" THERMAFIBER SAFB • 5/8" SHEETROCK Brand FIRECODE Core Gypsum Panels – optional veneer plaster 	UL Des U329		SA700	25
wt. 7 	<ul style="list-style-type: none"> • 5/8" SHEETROCK Brand Type X Exterior Sheathing or 5/8" FIBEROCK Brand AQUA-TOUGH Exterior Sheathing • 5/8" SHEETROCK Brand FIRECODE Core Gypsum Panels or SHEETROCK Brand Water-Resistant FIRECODE Core Gypsum Panels, interior side – 2x4 wood studs 16" o.c. – joints exposed or finished 	UL Des U305, U314		SA700	26
2 Hour Fire-rated Construction					
wt. 12 	<ul style="list-style-type: none"> • 5/8" SHEETROCK Brand Type X exterior sheathing or FIBEROCK Brand AQUA-TOUGH Exterior Sheathing on exterior side • double layer 5/8" SHEETROCK Brand FIRECODE Core Gypsum Sheathing or SHEETROCK Brand Water-Resistant FIRECODE Core Gypsum Panels on interior – 2x4 wood stud 16" o.c. 	UL Des U301		SA700	27
	<ul style="list-style-type: none"> • 5/8" SHEETROCK Brand FIRECODE Core Gypsum Panels, interior side – 2x4 wood stud 16" o.c. • 1/2" FIBEROCK Brand AQUA-TOUGH Exterior Sheathing or SHEETROCK Brand Gypsum Sheathing – joints finished 	UL Des U302		SA700	28
	<ul style="list-style-type: none"> • 1/2" DUROCK Brand Cement Board • base layer 5/8" SHEETROCK Brand FIRECODE Core Gypsum Sheathing – 2 x 4 wood studs 16" o.c. – 3" THERMAFIBER SAFB – joints taped • 5/8" SHEETROCK Brand FIRECODE Core Gypsum Panels 	UL Des U308		SA934 SA700	29

Design Details

Weather Barrier Installation

Step 1

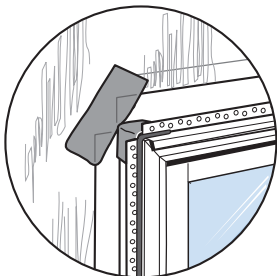

Step 2

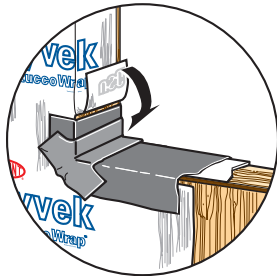

Step 3

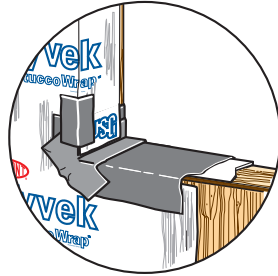

Typical Wall Section at Window

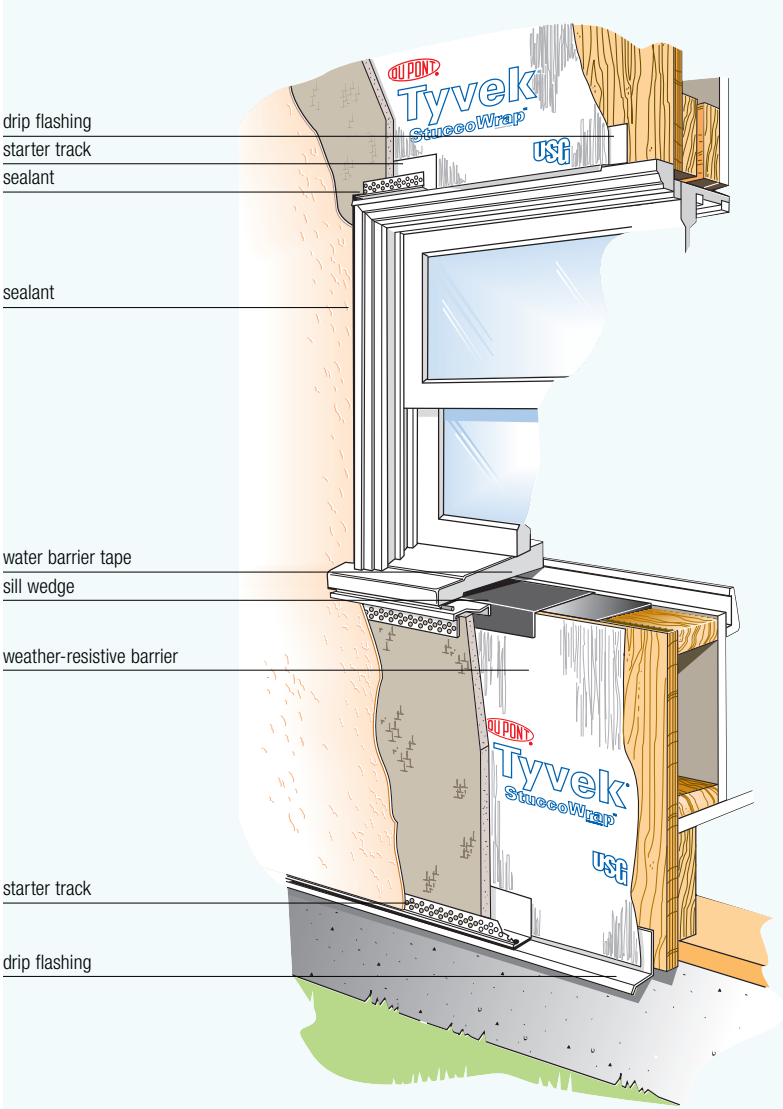

Note
Further information can be found
in Good Design Practices.

Design Details

Typical Roof/Wall Installation

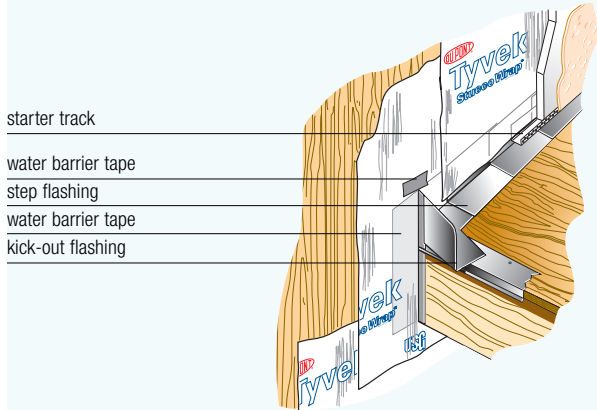

Typical Wall at Soffit

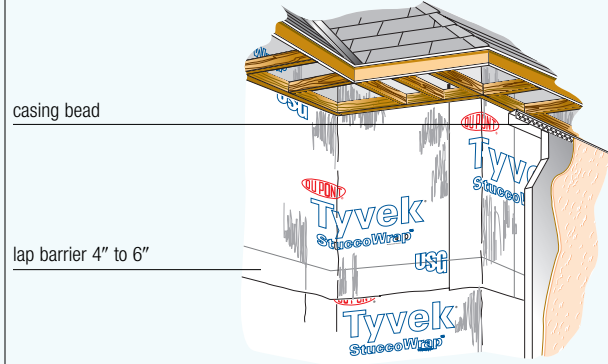

Typical Control Joint at Intermediate Floor

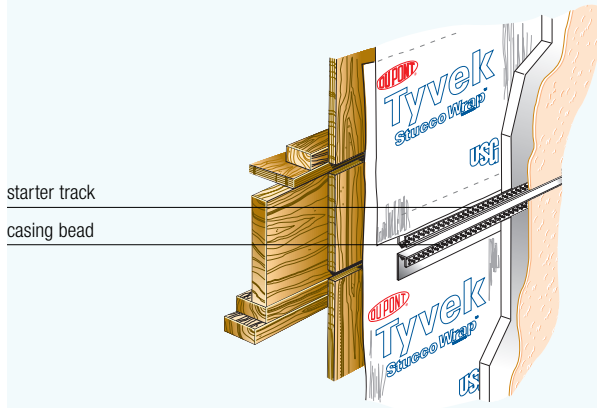

Typical Wall at Outside Corner

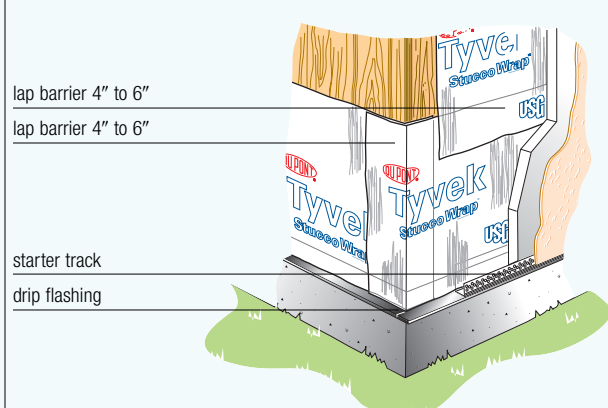

Typical Wall at Pipe/Penetration

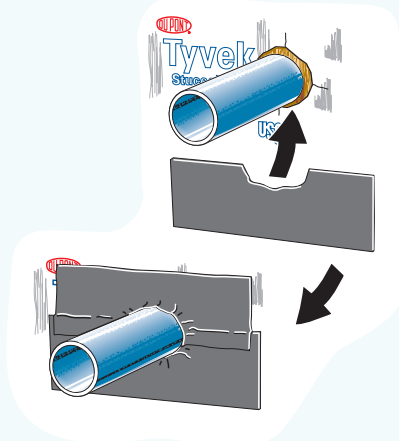

Typical Roof/Wall Drawer

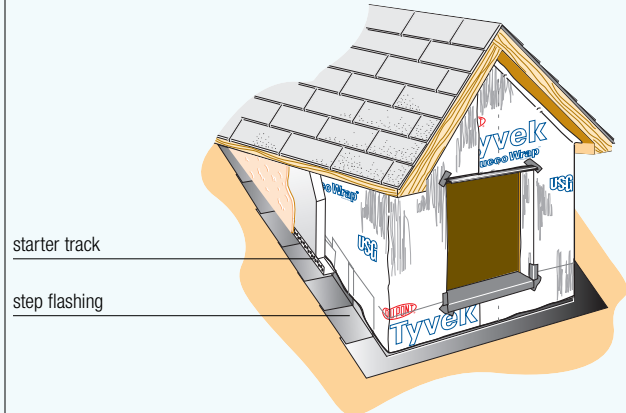

Good Design Practices

This section is an overview of good design, application, installation and safety concerns that should be addressed when USG's products and systems are used. This section outlines some major issues, but is not intended to be a comprehensive review. No attempt is made at completeness.

We recommend that architects and contractors seek the assistance of safety professionals, especially at the professional construction site, because there are many factors to consider that are not included here. These products must not be used in a design or construction without a complete evaluation by a qualified structural engineer or architect to verify suitability of a particular product for use in the structure. For more information on safety and material handling, please refer to Chapter 13 in *The Gypsum Construction Handbook, Centennial Edition*.

1 System Performance United States Gypsum Company conducts tests on products and systems to meet performance requirements of established test procedures specified by various agencies. Upon written request we will provide test certification for published fire, sound, structural and other pertinent data covering systems designed and constructed according to our published specifications.

The following standards apply:

ASTM C79: Standard Specification for Gypsum Sheathing Board

ASTM C1278: Standard Specification for Fiber-Reinforced Gypsum Panel

ASTM C1325: Standard Specification for Non-Asbestos Fiber-Mat Reinforced Cement Substrate Sheets

ASTM C1396: Standard Specification for Gypsum Board

ASTM C1397: Standard Practice or Application of Class PB Exterior Insulation and Finish Systems

2 EIFS Substrates Insulation board may be mechanically applied over a weather-resistive barrier to SHEETROCK Brand Gypsum Sheathing, DUROCK Brand Cement Board and FIBEROCK Brand AQUA-TOUGH Sheathing in a properly designed EIFS system.

DUROCK Brand Cement Board and FIBEROCK Brand AQUA-TOUGH Sheathing are the only substrates that have the bonding qualities that permit adhesive application of the insulation.

Water-sensitive substrates such as SHEETROCK Brand Gypsum Sheathing should not be used for adhesively attached EIFS, since there is a potential for the substrate to deteriorate as a result of water intrusion.

3 Fasteners for DUROCK Brand Cement Boards and FIBEROCK Brand Sheathing Specify 1-1/4" DUROCK Brand or USG Brand Sheathing Type SF Screws for fastening panels to 14- to 20-ga. framing. Specify 1-1/4" or 1-5/8" DUROCK Brand or USG Brand Sheathing Type WF Screws or 1-1/2" 11 ga. hot-dipped galvanized roofing nails with nominal 7/16" diameter head for attaching panels to wood studs.

Good Design Practices

4 Basecoats	The basecoat is a key element in the aesthetics, durability and water resistance of the EIFS surface lamina. It is critical that the basecoat layer be applied in strict compliance with the manufacturer's specifications. The basecoat thickness should be a minimum wet state 1/16" and the pattern of the mesh should not be visible through the basecoat immediately after application.
5 Exterior Insulation Board	Do not allow the insulation board to be left in the sun for prolonged periods of time either on the wall surface before basecoating or while in storage. If the EPS insulation board turns yellow or hardens while on the wall surface due to UV exposure, the affected EPS material should be removed by surface rasping and smoothing.
6 Exterior Finish	<p>Appearance of finish will vary depending upon the color and texture combination used, the tools with which finish is applied, and the natural variations of application technique occurring among the applicators performing the work.</p> <p>It is important to mix and apply each batch of the textured finish in the same manner. Variations in the texture and absorption of the basecoat will affect the appearance of the finish. The use of a primer over the basecoat is recommended to equalize its absorption and color, particularly when fine texture finishes are used. Provide enough workers to avoid cold joints in finish; stop and start application at natural breaks in exterior wall, such as corners, control joints and wall elevation changes.</p> <p>Exterior finish is a waterborne coating that dries by the evaporation of water. High humidity, cool temperature and lack of air movement will naturally delay the drying of the finish. Excessive delay in drying can adversely affect the appearance of the finish and lead to wash-off if exposed to running water. This is not a defect in the material.</p> <p>Exterior finish contains naturally occurring minerals that occasionally can oxidize and discolor the finish in small spots. This is not a defect in the material.</p> <p>Field coloring or tinting of exterior finish can result in color and texture variation from pail to pail that may affect the uniform finish appearance.</p>
7 Structural Bracing	All steel stud framed construction must be diagonally and laterally braced as required to carry shear loads and to prevent stud rotation. Space lateral bracing a maximum of 4' o.c. Drywall can be used for lateral bracing provided it is installed prior to joint treatment and finishing of the exterior system.
8 Crack Resistance	Steel frame construction has a greater tendency to move when subjected to wind loads and temperature changes. To lessen the potential of this movement to cause cracking in Direct-Applied Exterior Finish Systems, reinforce the basecoat with reinforcing mesh or use elastomeric coating systems.
9 Window and Door Openings	<p>Windows and doors may permit some water to pass through the frame material or joints. To reduce the potential for intruding water to degrade water-sensitive sheathing and framing, and to keep water out of the stud cavity, it is required that the rough opening be properly protected and a means provided to allow intruding water to escape. Avoid details that trap water and follow the window and door manufacturers' recommendations for proper installation.</p> <p>All window and door openings must be properly flashed, weeped and caulked. Consult the EIFS manufacturer for assistance with proper detailing.</p>

10 Shadowing and Spotting

When the outside temperature differs considerably from the building's interior temperature, airborne dirt can accumulate on the colder regions of exterior walls causing "shadowing" or "spotting," particularly over fasteners and framing. This is a natural phenomenon, which occurs through no fault in the products.

Where temperature, humidity and soiling conditions are expected to cause objectionable blemishes, provide a thermal separation between the interior and exterior faces.

Care should be taken to remove scaffolding immediately after the application of finish to avoid having the image of the scaffolding become imprinted on the finish as a result of differential drying in shaded areas.

11 Control Joints, Building Expansion Joints and Trims

It is the responsibility of the architect/engineer to properly design and detail expansion joints. This includes joint locations, joint width and selection of joint sealant material.

Do not use surface-mounted reveals, control joints and trims other than those recommended by United States Gypsum Company or the cladding manufacturer. To lessen the potential for edge cracking and delamination, use casing-bead-type control joints, trims and reveals. Zinc control joints and trims are not recommended for use with USG exterior sheathing panels. A control joint or expansion joint should be placed in the wall surface:

- At all building expansion joints
- At intersections of dissimilar substrates or finishing materials
- At other major building discontinuities
- At all floor lines in wood-frame construction
- At all locations where concentrated stress or movement is anticipated

Maximum surface control joint spacing for tile and thin brick finishes is 16' in either direction. In DuROCK Brand DEFS, vertical control joints are only required in the locations indicated above. Steel framing at building control joints that extend through the wall (with top and bottom runner tracks broken) should have 1-1/2" cold-rolled channel alignment stabilizers spaced a maximum of 5'0" o.c. vertically.

Sheathing panels should be separated at all surface and building control joints. Where vertical and horizontal joints intersect, the vertical joint should be continuous and the horizontal joint should abut it. Splices, terminals and intersections should be caulked with a sealant complying with architectural practices and sealant manufacturer recommendations. Do not apply tile or finishes over caulked or sealed expansion joints.

12 Air and Water Infiltration

The USG exterior sheathing product line provides substrates for use in water-managed systems. USG recommends water-management type claddings. These systems have a positive provision for the drainage of water if the primary face sealants leak. Special attention should be placed on design and proper installation of joints, openings and penetrations. Provide normal care and maintain the face of the facade to keep water from penetrating the surface. Flashing, weeping and sealants as shown in the details must be provided to resist air and water infiltration.

DuROCK Brand Cement Board is not a water barrier. A continuous water barrier must be installed over the studs and lap over the flashing. Weeps must be provided to allow for water drainage out of the system at all horizontal terminations. Choosing the proper size and design of flashings is the responsibility of the design professional.

13 Vapor Retarders

Water vapor control must always be considered in the design of exterior wall systems. Humidity and temperature conditions may require the installation of a vapor retarder to prevent moisture condensation within the wall. To determine the necessity and location of vapor retarders, a water vapor transmission and dew point analysis of the layered wall assembly should be conducted by a qualified engineer.

Good Design Practices

14	Soffits and Ceilings	As in walls, mechanical fasteners must be used to apply insulation over SHEETROCK Brand Gypsum Sheathing on soffits to provide protection against potential delamination if moisture were to accumulate on the back side of the EIFS soffit for any reason. Adhesive application of insulation and textured finish is permitted over DUROCK Brand Cement Board and FIBEROCK Brand AQUA-TOUGH Sheathing. DUROCK Brand Cement Board finished with ceramic tile and thin brick may be used on properly vented soffits and ceilings with DUROCK Brand Screws spaced 6" o.c. maximum. SHEETROCK Brand Exterior Ceiling Board is also applicable. A qualified structural engineer should evaluate design, including uplift bracing.
15	Joint Sealants	It is recommended that all joint materials be bonded to the cementitious basecoat or trim material. It is the responsibility of the architect and sealant manufacturer to ensure that the selected sealant is compatible with what it is bonded to on both sides of the joint, i.e., the EIFS basecoat material and a window or door frame. It is recommended that openings be properly prepared before installing windows and doors.
16	High-Traffic Areas	For high-traffic areas, such as first-level storefronts, schools, or where lines may form, install heavy-duty or high-impact reinforcing mesh and basecoat followed by the standard mesh, or consider the use of DUROCK Brand Cement Board in a DEFS application.
17	Surface-Mounted Objects	EIFS Applications—Do not attach a surface-mounted object, such as a sign, handrail or mailbox, to the EIFS lamina. Surface-mounted objects should be attached through the EIFS and directly into the building structure, i.e., stud frame or concrete block. These penetrations should then be properly sealed. Consult the EIFS manufacturer for assistance in review of your design.
18	Leaching and Efflorescence	Latex leaching and efflorescence are natural phenomena which occur with the use of latex-modified mortars and grouts through no fault in the products. To help protect against occurrence, follow current ceramic tile industry guidelines and recommendations.
19	Corrosion Protection	All architectural components, such as anodized aluminum window frames, trims, flashings and casings, should be protected from alkaline building materials such as cement board, portland cement basecoats, mortars and grouts.
20	Application at Grade	USG sheathing panels are not designed for below-grade applications. Height above grade should be a minimum of 8". Use appropriate waterproofing and damp-proofing products below grade.

Application Guide

Specifications

This guide is provided to assist you in specification of USG exterior substrate products. If you have additional questions or would like more information regarding this or other USG products and systems, please contact USG at 800.USG.4YOU.

Part 1: General

1.1 Scope

Specify to meet requirements.

1.2 Qualifications

All materials, unless otherwise indicated, shall be manufactured by or for United States Gypsum Company, and shall be installed in accordance with its current printed directions.

1.3 Delivery and Storage of Materials

All materials shall be delivered in their original unopened packages and stored in an enclosed shelter providing protection from damage and exposure to the elements. Damaged or deteriorated materials shall be removed from the premises.

Warning: Store all SHEETROCK Brand Gypsum Panels, FIBEROCK Brand AQUA-TOUGH Sheathing and DUROCK Brand Cement Board flat. Panels are heavy and can fall over, causing serious injury or death. Do not move unless authorized. Use caution not to exceed floor limits or cause tripping hazards.

1.4 Environmental Conditions

Finishes, leveling/skim coats, basecoats, insulation board and reinforcing mesh shall not be applied at temperatures below 40 °F (4 °C) or to substrate that is wet, frozen or contains frost. After application, and for at least 24 hours, finishes, leveling/skim coats and basecoats shall be effectively protected from rain, moisture and temperature below 40 °F (4 °C).

Hot and dry weather may affect working time of leveling/skim or basecoat and finish materials. Under rapid drying conditions, dampening of board, leveling/skim or basecoat surface may be required to improve workability.

1.5 Framing

Steel or wood framing shall be structurally sound, free from bow, and in general compliance with local building code requirements. Damaged and bowed framing shall be replaced before installation of panels.

Framing shall be designed (based on stud properties alone) not to exceed L/240 for EIFS and DEFS; L/360 for DUROCK Brand Ceramic Tile Systems. Steel framing must be 20 ga. or heavier with a minimum G60 hot dipped galvanized coating.

Application Guide

Specifications

1.6 Quality Assurance

A. Qualifications

1. Manufacturer shall have experience in manufacturing exterior products and systems that have a record of successful in-service performance.
2. Contractor shall have successfully installed several projects of a similar type, size and geographical location as this project within the past five years. These past projects shall have resulted in construction with a record of successful in-service performance.

B. Mock-Ups

Prior to installation of the system, erect adequately sized mock-ups for each form of wall construction and finish required to verify detailing and selections made under sample submittals and to demonstrate aesthetic effects including those related to Part 3: Execution. Build mock-ups using materials indicated for final work. Locate mock-ups onsite and build to the size indicated by the architect.

C. Preinstallation Conference

At least one (1) week prior to starting work, conduct a preinstallation conference at the project site. Parties present shall include, but not be limited to, the general contractor, contractor, architect, Owner's Representative for inspection, sealant contractor and window contractor.

D. Field Quality Control

At frequent intervals during construction, the job site shall be visited by the Owner's Representative to confirm that the USG sheathing system is being installed per specification.

Part 2: Products

2.1 Materials Supplied by United States Gypsum Company

A. Substrates

DUROCK Brand Cement Board, FIBEROCK Brand AQUA-TOUGH Sheathing and SHEETROCK Brand Gypsum Sheathing—see Components.

B. Accessories

Screws (DUROCK Brand steel screws or USG Sheathing Type SF Screws for steel framing or DUROCK Brand wood screws or USG Sheathing Type WF Screws for wood framing)—see Related Products. Tape (DUROCK Brand Alkali-Resistant Tape).

C. Interior Surfaces

1. Gypsum Panels—Specify from SA927, *Gypsum Panels and Accessories*
2. Veneer Plaster—Specify from SA920, *Plaster Systems*
3. Ceramic Tile—Specify from SA934, *Moisture-Resistant Assemblies*

2.2
Materials Supplied
By Others

- A. Nails**
Minimum 1-1/2" 11 ga., hot-dipped galvanized roofing nails with nominal 7/16" diameter head for wood framing.
- B. Sealant**
Shall be approved by the manufacturer for use on the exterior and tested for compatibility with the substrate and exterior basecoat and finish materials. Sealant should be low modulus, having a minimum joint movement capability of 50% with 100% recovery such as Dow Corning 790 and 795 Silicone Building Sealants or equivalent. EIFS materials shall be fully cured prior to sealant installation.
- C. Screws**
1-1/4" self-drilling bugle head corrosion-resistant screws for application of gypsum sheathing to steel studs. 1-1/4" Type S-12 pancake head corrosion-resistant screws for application of self-furring metal lath or brick ties through sheathing to studs.
- D. Insulation Board Mechanical Fasteners**
WIND-LOCK Brand Fasteners or equivalent.
- E. Insulation Board**—contact EIFS manufacturer
- F. Basecoat**—contact EIFS manufacturer
- G. Exterior Finish**—contact EIFS manufacturer
- H. Staples**
Stainless steel with divergent points nominal 3/8" leg, 1/2" crown (obtain locally) for attaching trim. For attaching FIBEROCK Brand AQUA-TOUGH Sheathing to wood framing, use 7/16" crown, 15 or 16 wire gauge in varying leg lengths from 1-1/4" to 2-1/4".
- I. Exterior Grade Ceramic Tile, Thin Brick and Thin Cut Stone Tile**—contact supplier for suitability of adhered veneers for DUROCK Brand Cement Board.
- J. Membrane—Weather-Resistive Barrier**
TYVEK STUCCOWRAP Weather-Resistant Barrier, No. 15 asphalt felt, Grade D, 60-minute building paper or equivalent water and air infiltration barrier.
- K. Flashing**
Corrosion-resistant for added resistance to water penetration in all exterior systems.
- L. Trim**
Termination trims made of exterior-grade rigid polyvinyl chloride (PVC) or aluminum and approved for suitability by United States Gypsum Company, the exterior finish system manufacturer and the trim manufacturer, such as Fry Reglet Aluminum Architectural Moldings, Vinyl Corporation or Plastic Components Inc.

Application Guide

Specifications

Part 3: Execution

3.1 Framing Erection

Space wood and steel framing a maximum of 16" o.c. for Durock Brand Cement Board and 24" o.c. for FIBEROCK Brand AQUA-TOUGH Sheathing. Adequate diagonal bracing meeting design requirements must be installed prior to application of substrate. Lateral bracing of steel framed curtain walls is required prior to finishing exterior walls. The studs of freestanding furred walls must be secured to exterior wall with wall furring brackets or laterally braced with horizontal studs or runners spaced 4' o.c. maximum.

3.2 Expansion Joints

Location and design of building expansion joints shall be the responsibility of the Architect/Engineer of Record. Control joint spacing shall be maximum 16' o.c. for Durock Brand Ceramic Tile Systems. As a minimum for DEFS and EFS installations, expansion joints shall be installed at all building expansion joints, at the intersection of dissimilar substrates or finishing materials, or other major building discontinuities, and at all floor-lines in wood-frame construction.

3.3 Flashing

Flash and weep all horizontal terminations. At all window and door openings, wrap the weather-resistive barrier around the jambs and wrap the sill with water barrier tape. At window sills, use a sloped sill wedge or alternate method of sloping at sill to direct moisture to the exterior face of the weather-resistant barrier. Apply head flashing and casing beads or back-wrap as required, providing the required space around the window to allow for the proper application of the sealant system.

3.4 Gypsum Sheathing Application

When installing any gypsum sheathing product, use standard gypsum board construction practices such as staggering joints and L-cutting panels around openings.

A. SHEETROCK Brand Gypsum Sheathing Application

1. Apply 1/2" x 24" x 8' SHEETROCK Brand Gypsum Sheathing horizontally with face side out (paper on back is lapped at edges). Place tongue edge up to prevent water penetration at joints. Use diagonal bracing where necessary. Space 1-1/4" screws or 1-3/4" 11 ga. galvanized roofing nails 8" o.c. on framing members.
2. Apply 1/2" or 5/8" x 48" x 8' or 9' SHEETROCK Brand Gypsum Sheathing horizontally or vertically with face side out. Space 1-1/4" screws or 11 ga. galvanized roofing nails 8" o.c. on framing members.

B. Corner Braces

When required, install 1" x 4" diagonal corner braces, or equal, at all external corners, let into face of studs, corner posts, sill and plates, or as required by applicable code. On steel framing secure steel strap bracing or equivalent as required by design or code.

C. Membrane

TYVEK STUCCOWRAP or an equivalent weather-resistive barrier should be installed over gypsum sheathing prior to exterior surfacing application in water-managed, flashed and weeped systems.

D. Exterior Surfacing Application

1. Wood, Vinyl or Aluminum Siding—Drive nails through sheathing and into studs for minimum penetration of 1-1/4" into studs. Butt end joints of siding over centers of studs.
2. Masonry Veneer—Provide clear space of at least 1" between back of masonry and face of sheathing. Attach masonry ties to wood studs with nails driven through sheathing and into studs. Use nails penetrating at least 1-1/4" into studs (at least 6d common nails). Anchor brick with approved brick ties, screw-attached to each steel stud using 1-1/4" self-drilling pancake head corrosion-resistant screws. Anchor other masonry units to each stud in a similar manner, 16" o.c. maximum or as recommended by Brick Institute of America.
3. Conventional Stucco—Provide clear space of at least 1/4" between back of stucco lath and face of sheathing. Use 3.4 lb. self-furring diamond mesh metal lath galvanized applied with nails penetrating at least 1-3/8" into wood studs. Apply portland cement-lime basecoat and stucco finish coat over lathed sheathing. For curtain wall construction, attach metal lath to steel studs and runners through sheathing with 1-1/4" self-drilling pancake head corrosion-resistant screws spaced 8" o.c. (see ASTM C926).
4. Other Exterior Surfacing—Apply with mechanical fasteners through sheathing into the framing. Consult exterior surfacing manufacturer for other details.
5. Pressure Equalized Rain Screen System Brick Veneer—Provide clear space of at least 1" between back of masonry and face of sheathing. Attach masonry ties to wood studs with nails driven through sheathing and into studs. Use nails penetrating at least 1-1/4" into studs (at least 6d common nails). Anchor brick with approved brick ties, screw-attached to each steel stud using 1-1/4" self-drilling pancake head corrosion-resistant screws. Anchor other masonry units to each stud in a similar manner, 16" o.c. maximum or as recommended by Brick Institute of America. Provide an air cavity behind the exterior cladding that is connected to the outside air.

**3.5
Mechanically
Attached EIFS**

A. Site Inspection and Preparation

Inspect the sheathing substrate to ensure that it is free of foreign materials and that its is securely fastened to the framing and is free of voids, surface delaminations, projections or surface deterioration. Apply the Starter Track and water-resistive barrier over the substrate.

B. Membrane—Weather-Resistive Barrier

1. TYVEK STUCCOWRAP Weather-Resistance Barrier shall be installed horizontally over sheathing. Lap weather-resistive barrier 4" to 6" at all joints in shingle-like manner (bottom course installed first) to prevent water penetration. Wrap weather-resistive barrier into opening around jamb, framing members. Do not wrap the weather-resistive barrier around the window or door header. Lap weather-resistive barrier over properly designed flashings.
2. For wood framing, plywood or SHEETROCK Brand Gypsum Sheathing, staple membrane to substrate and immediately apply insulation board. Note: For wet climates when TYVEK STUCCOWRAP Weather-Resistant Barrier is not used, it is recommended that a grooved insulation board or furring lath over No. 15 asphalt felt or Grade D, 60-minute building paper be installed when standard EPS insulation board is used.

Application Guide

Specifications

C. EIFS Application—follow EIFS Manufacturer's Instructions

1. Insulation board, 1" minimum thickness, shall be applied starting at the bottom. The first course shall be fit into the Starter Track (termination trim with weep holes). The insulation boards shall be held up 1/16" to 3/16" from the bottom of the Starter Track to allow for drainage. The joints shall be offset 8" minimum from the joints in the substrate. Alternately lap insulation boards at corners.
2. Precut the insulation board into L-shaped pieces to fit around door and window openings. Joints shall not align with corners of windows, doors or other wall penetrations.
3. Attach minimum 1" thick insulation board, through the weather-resistive barrier and sheathing, into the framing using the appropriate WIND DEVIL® Fastener by Wind-lock Corporation (or equivalent).
4. Install mechanical fasteners such that plastic washers are flush with the insulation board surface. At no time shall the washer head penetrate the insulation board surface greater than 1/16".
5. Apply basecoat and reinforcing mesh as specified in 3.6 F.
6. Finish Coat—Apply Textured Finish as specified in Section 3.6 H.

3.6 **Adhesively** **Attached EIFS** **Applications**

A. Site Inspection and Preparation

Steel or wood framing to receive DUROCK Brand Cement Board or FIBEROCK Brand AQUA-TOUGH Sheathing shall be structurally sound, free from bow and in general compliance with local building code requirements. Damaged and/or bowed framing shall be replaced before installation of the FIBEROCK Brand AQUA-TOUGH Sheathing or DUROCK Brand Cement Board. Apply the Starter Track and water-resistive barrier over the framing for water-managed EIFS.

B. Membrane—Weather-Resistive Barrier

For Water-Managed EIFS, brick veneer and pressure-equalized rain screen systems.

1. For steel framing, secure TYVEK STUCCOWRAP Weather-Resistant Barrier to studs with tape or adhesive and immediately apply DUROCK Brand Cement Board or FIBEROCK Brand AQUA-TOUGH Sheathing.
2. For wood framing, plywood or gypsum sheathing, staple TYVEK STUCCOWRAP Weather-Resistant Barrier to framing or substrate and immediately apply FIBEROCK Brand AQUA-TOUGH Sheathing or DUROCK Brand Cement Board.

C. Membrane—Barrier EIFS

No weather-resistive barrier is required.

D. Panel Application

1. Apply DUROCK Brand Cement Board with rough side toward exterior or FIBEROCK Brand AQUA-TOUGH Sheathing with smooth side toward the exterior. When panels are installed horizontally, the ends must be supported. When panels are installed vertically, the edges must be supported. Fit ends and edges closely, but not forced together. For panel with staple-attached membrane, apply in a shingle-like manner beginning at bottom of wall. Stagger end joints in successive courses.
2. Fasten panels to framing with specified fasteners. Drive fasteners in field of panel first, working toward ends and edges. Hold panel in firm contact with framing while driving fasteners. Space fasteners maximum 8" o.c. for DUROCK Brand Cement Board walls, 12" o.c. for FIBEROCK Brand panel walls, 6" o.c. for ceilings, with perimeter fasteners at least 3/8" and less than 5/8" from ends and edges. Drive nails and screws so bottoms of heads are flush with surface of DUROCK Brand Cement Board, to provide firm panel contact with framing. Do not overdrive fasteners.

-
3. DuROCK Brand Cement Board should be cut to size using a utility knife and a straight edge. FIBEROCK Brand panels should be cut with a power shear. A power saw may be used to cut either panel only if it is equipped with a dust collection device. Worker should wear NIOSH/MSHA-approved respirator.
 4. Install Starter Track on framing or substrate prior to installation of the board. Select appropriate size Starter Track and/or flashing for the system specified.
 5. Follow Section 3.2 for expansion joint application.

E. Insulation board—follow EIFS Manufacturer’s Recommendations

1. Insulation board, 1” minimum thickness, shall be applied starting at the bottom. The first course shall be supported by the Starter Track. The insulation board shall be installed with the long edges horizontal using a running bond pattern. The joints shall be offset 8” minimum from the joints in the substrate. Alternate lap of insulation board at corners.
2. Precut the insulation board into L-shaped pieces to fit around door and window openings. Joints shall not align with corners of windows, doors or other wall penetrations.
3. Use insulation board adhesive or basecoat for adhesively attaching insulation board to DuROCK Brand Cement Board or FIBEROCK Brand AQUA-TOUGH Sheathing.
4. Any gaps 1/8” or larger between insulation boards shall be filled by cutting and shaping slivers of insulation board to fit the gap and inserting them without using the basecoat/adhesive.
5. Allow the insulation board application to dry or cure for a minimum of 24 hours before rasping of insulation board or applying the reinforcing mesh and basecoat material. Protect insulation from exposure to rain, freezing conditions and physical damage until basecoat is fully dried or cured.

F. Basecoat and Reinforcing Mesh—follow EIFS Manufacturer’s Recommendations

1. Before applying the basecoat and reinforcing mesh, all insulation board must be rasped to enhance bonding of basecoat, level out-of-plane edges and remove dirt and weathering damage. Do not prefill low areas with basecoat materials.
2. Cut grooves or other design features into the insulation surface as required. The minimum thickness of the exterior insulation board after routing shall be 3/4” at all points. Install special foam shapes to either the substrate or the surface of the insulation board as required.
3. Mix the basecoat according to instructions on packaging.
4. Using a stainless steel trowel, apply a uniform layer of basecoat to the insulation board. Immediately embed the reinforcing mesh, with its concave surface facing the wall, into the wet basecoat material and smooth with a trowel until the mesh is fully embedded. Smooth out wrinkles by working from the center to the edges. At this point, the basecoat thickness should be equal to the mesh thickness. After several minutes of mesh embedment and while the previously applied basecoat is still wet, the applicator shall double-back with a second layer of additional basecoat and smooth the surface to give a minimum wet basecoat thickness of 1/16”. The pattern of mesh should not be visible through the basecoat immediately after application.
5. Reinforcing mesh shall be lapped a minimum of 2” on all sides of each adjoining piece and be wrapped around corners from both directions for a minimum of 8”. Back- or edge-wrap the insulation board a minimum of 2” at all terminations as required. Reinforce wall penetrations with minimum 9” wide by 12” long pieces of Detail Weight Mesh applied at 45° angle to corners.
6. Allow the basecoat to cure for a minimum of 24 hours before application of the primer or textured finish.

Application Guide

Specifications

- G. Primer**—follow EIFS Manufacturer's Recommendations
- H. Textured Finish**—follow EIFS Manufacturer's Recommendations
 1. Inspect basecoat for defects; repair prior to application of finish.
 2. Mix the textured finish according to instructions printed on pails.
 3. Trowel-apply Textured Finish in a minimum 1/16" thick, uniform layer over all basecoated surfaces. Do not add sand or other additives to create heavier textures.
 4. Apply finish in a continuous operation without cold joints or scaffolding lines. A wet edge shall be maintained. Continuous work shall proceed toward joints and corners. Sufficient manpower and scaffolding shall be employed to ensure continuous application and a uniform finished appearance.
 5. Texture finish as required using only plastic or wood floats.
 6. Bring finish only a short distance into joints and returns (approximately 1/4") such that sealant materials bond primarily to the basecoat but still cover up the edge of the finish.
 7. Allow finish to dry for a minimum of 24 hours. Protect finish from weather, dust, and physical damage until fully dried.

3.7 Applications

- A. Membrane—Water Barrier**

Apply membrane as specified in Section 3.6 B.
- B. Cement Panel Application**

Apply Durock Brand Cement Board as specified in Section 3.6 D.
- C. Joint Reinforcement**

For tile and thin brick finishes, prefill joints with latex-modified portland cement mortar. Embed Durock Brand Exterior Tape centered over all joints and corners but not overlapped. For Direct-Applied Exterior Finish System, prefill joints with basecoat and immediately embed 4" Durock tape and level the joints.
- D. Trim Accessories**

Trim accessories are applied using Durock Brand Screws or USG Sheathing Screws or hot-dipped galvanized roofing nails, spaced 6" to 9" o.c. in each flange. If additional attachment is needed, use stainless steel staples, spaced 6" to 9" o.c. in each flange.

Treat trim accessories with basecoat and tape; then level with adjacent board areas. Fill all voids and depressions with basecoat and feather mortar edges. The treated joints and trim areas must be allowed to cure for a minimum of 4 hours before application of basecoat.
- E. Basecoat and Finish**—follow DEFS Manufacturer's Recommendations
 1. Basecoat—Follow exterior finish manufacturer's recommendations. Apply a 1/16" minimum thick, uniform layer of basecoat over the entire surface after joints and trim have cured a minimum of 4 hours. To fill and level surface depressions caused by framing irregularities, apply basecoat to low areas first. Trowel flush with adjacent areas before application over entire surface. Leave surface smooth and flat. Under rapid drying conditions, dampen surface as necessary to improve workability. Allow basecoat to dry 24 hours before application of Textured Finish. For steel-framed applications, embed reinforcing mesh over the entire wall surface with basecoat.
 2. Finish Coat—Apply Textured Finish as specified in Sections 3.6 G and 3.6 H.

F. Layered Details

To create bands, quoins, dentils and other layered details, cut Durock Brand Cement Board or insulation to specified size and shape. Laminate to basecoated Durock Brand Cement Board following same application procedure as with ceramic tile or EIFS.

**3.8
Durock Brand
Ceramic Tile
Applications**

A. Thin Brick and Ceramic Tile Systems

1. Skim Coat—Apply a 1/8" minimum leveling/skim coat of latex modified thin-set mortar uniformly over Durock Brand Cement Board surfaces. Leave surface smooth and flat. Allow to set 24 hrs. before application of bond coat for setting tile and thin brick.
2. Tile Setting—Ceramic tile and thin brick on walls may not exceed 3/4" thickness, 18"x18" size, and 10 psf. Ceramic tile and thin brick should be installed in accordance with ANSI 108.5 specifications and manufacturer's directions. Using the notched trowel required for the thickness of thin brick or tile being installed, apply latex-modified portland cement mortar to obtain uniform setting bed. Back-butter the (thin brick) (ceramic tile) for 100% mortar contact. Install units by firmly pressing them into freshly applied mortar. Use a sliding and twisting motion to embed units and obtain a 100% mortar contact. Beat-in ceramic tile in accordance with accepted practice. Apply latex-modified portland cement grout after mortar has set firmly for 24 hours. Mix and apply grout according to directions on packaging. Force maximum amount of grout into joints. Tool and compress grout into joints to provide neat and uniform appearance. Clean grout from finished surfaces and cure installation as required by ANSI A108.10 Specification.

**3.9
Conventional
Stucco
Application**

A. Conventional Stucco Applications

1. Install SHEETROCK Brand Gypsum Sheathing, FIBEROCK Brand AQUA-TOUGH Sheathing or Durock Brand Cement Board as described in Part 3.
2. Apply flashings as specified at all horizontal terminations including the base of walls and the heads of windows and doors.
3. Install TYVEK STUCCOWRAP or building paper over the sheathing or use a paper-backed metal lath.
4. Apply the new portland cement stucco scratch coat and allow it to cure for a minimum of 48 hours to minimize cracking prior to application of the brown coat. The brown coat shall have been air-dried a minimum of seven days or have achieved a safe reading on a stucco moisture meter before application of the finish coat.
5. Finish Coat—Apply the textured finish as specified by the finish manufacturer.

Application Guide

Specifications

System Limitations

For Exterior Insulation and Finish Systems (EIFS)

1. Maximum stud spacing shall be 16" o.c. or 24" o.c. for FIBEROCK Brand AQUA-TOUGH Sheathing. Maximum allowable deflection, based on stud properties only, shall be L/240.
2. Systems may not be used on exposed horizontal surfaces, such as window sills and parapet caps. These areas must be properly waterproofed and maintained.
3. EIFS are intended for buildings where the design wind load does not exceed the capacity of the system. Contact your local United States Gypsum Company office for all applications beyond the scope of this literature.
4. EIFS walls have low drying potential when used in conjunction with warm-side vapor retarders. A vapor transmission and dew point analysis should be conducted by a qualified engineer.
5. For EIFS employing solid EPS or insulation in regions of the country where the rainfall exceeds 20" per year, apply TYVEK STUCCOWRAP Weather-Resistant Barrier or approved furring lath over conventional weather-resistive barriers.

For Direct-Applied Exterior Finish Systems (DEFS)

1. Systems using DUROCK Brand Cement Board are designed for allowable wind loads shown in the Wind Load Design Table in the Technical Data section of Performance Testing. Studs must be minimum construction-grade spruce/pine/fir or 20-ga. steel, G60 galvanized. Contact your United States Gypsum technical representative for applications beyond the scope of this literature.
2. Maximum stud spacing: 16" o.c. for exterior wall assemblies; maximum allowable deflection, based on stud properties only, L/360 for tile and thin brick finishes, L/240 for textured finish.
3. Parapet tops, sloped surfaces and sills must be adequately caulked, flashed, capped or covered with a material designed to provide long-term water-penetration resistance.
4. DUROCK Brand Cement Board may not be used as a structural sheathing; for racking resistance, separate bracing must be specified.
5. Direct-Applied Exterior Finish System on steel framing must be laterally braced. Reinforce the basecoat with reinforcing mesh.

Specification Compliance

DEFS and EIFS are designed to prevent gross water intrusion into the wall cavity. Failure to comply with finish manufacturer's specifications, good design practices and inspection/maintenance can result in water entry and potential wall damage to moisture-sensitive structural elements.

Technical Assistance and Consultation

Technical assistance and consultation are readily available from experienced technical representatives. For technical assistance on USG exterior substrate products and systems and for preparing project specifications, contact United States Gypsum Company.

About the cover:

Project

Milpitas City Hall

Milpitas, CA

Recipient of the 2003 AIA San Francisco

Excellence in Design Award

Architects

STUDIOS Architecture

San Francisco, CA

Photographer

©Tim Griffith



Technical Service

800 USG.4YOU

Web Site

www.usg.com

Samples/Literature

888 874.2450

Samples/Literature E-mail

samplit@usg.com

Samples/Literature/Fax

888 874.2348

Customer Service

800 950.3839

Metric Specifications

USG Corporation, through its operating subsidiaries, will provide metric conversions on its products and systems to help specifiers match metric design sizes. In addition, some products are available in metric dimensions from selected manufacturing plants. Refer to SA100, *Fire-Resistant Assemblies*, for additional information and a Table of Metric Equivalents.

Trademarks

The following trademarks used herein are owned by United States Gypsum or a related company: AQUA-TOUGH, DURABOND, DUROCK, FIBEROCK, FIRECODE, IMPERIAL, SHEETROCK. DOW CORNING is a trademark of Dow Corning Corporation. WIND-LOCK and WIND DEVIL are trademarks of Wind-lock Corporation. FRY REGLET is a trademark of Fry Reglet Aluminum Architectural Moldings. THERMAFIBER is a trademark of Thermafiber LLC. TYPE S-12 is a trademark of ITW Buildex. TYVEK and STUCCOWRAP are trademarks of DuPont Company. LEED is a trademark of U.S. Green Building Council.

Notice

We shall not be liable for incidental and consequential damages, directly or indirectly sustained nor for any loss caused by application of these goods not in accordance with current printed instructions or for other than the intended use. Our liability is expressly limited to replacement of defective goods. Any claim shall be deemed waived unless made in writing to us within thirty (30) days from date it was or reasonably should have been discovered.

Note

All products described here may not be available in all geographic markets. Consult your local sales office or representative for information.

Safety First!

Follow good safety and industrial hygiene practices during handling and installation of all products and systems. Take necessary precautions and wear the appropriate personal protective equipment as needed. Read material safety data sheets and related literature on products before specification and/or installation.

