

ICC-ES Evaluation Report

ESR-1222

Reissued December 1, 2011

This report is subject to renewal in two years.

www.icc-es.org | (800) 423-6587 | (562) 699-0543

A Subsidiary of the International Code Council®

DIVISION: 09 00 00—FINISHES
Section: 09 22 26—Suspension Systems
Section: 09 53 00—Acoustical Ceiling Suspension Assemblies

REPORT HOLDER:

USG INTERIORS, LLC
550 WEST ADAMS STREET
CHICAGO, ILLINOIS 60661
(800) 874-4968
www.usg.com
usg4you@usg.com

EVALUATION SUBJECT:

USG DONN®, SIMPLICITEE®, DONN FINELINE®, DONN CENTRICITEE™ AND DONN MERIDIAN® ACOUSTICAL TILE SUSPENDED CEILING FRAMING SYSTEMS; USG DONN PARALINE® SUSPENDED CEILING SYSTEM; DONN DRYWALL SUSPENDED CEILING SYSTEM; DONN SEISMIC COMPRESSION POST; AND ACM7 CEILING ATTACHMENT CLIP

1.0 EVALUATION SCOPE**Compliance with the following codes:**

2009 and 2006 *International Building Code*® (IBC)

Properties evaluated:

- Interior finish
- Fire resistance
- Structural

2.0 USES

The USG suspended ceiling framing systems described in this report are suspended, exposed framing, concealed ceiling assemblies used in fire-resistance-rated and non-fire-resistance-rated construction for applications as noted in this report. The Donn Telescoping Seismic Compression Post is used as a compression post located at the lateral force bracing locations for installation between the suspended ceiling framing members and the structural roof or floor members above the ceiling. The ACM7 ceiling attachment clip is used to connect main and cross runners to wall molding.

3.0 DESCRIPTION**3.1 Ceiling Framing and Ceiling Systems:**

3.1.1 Acoustical Tile Ceiling Framing Systems: The Donn, Smplicitee, Donn Fineline, Donn Centricitee and

Donn Meridian acoustical suspended ceiling framing systems consist of main and cross runner framing members for use with acoustical tiles.

3.1.2 Donn Paralane Suspended Ceiling System: The Donn Paralane suspended ceiling system consists of main and cross runner framing systems and Paralane pans used as ceiling tiles.

3.1.3 Donn Drywall Suspended Ceiling System: The Donn Drywall Suspended Ceiling System consists of main and cross runner framing systems for use with gypsum wallboard attached to the bottom of the framing members.

3.2 Donn Telescoping Seismic Compression Post:

The Donn telescoping seismic compression post consists of a $\frac{3}{4}$ -inch-diameter (19.05 mm) tube inserted within and projecting out of a 1-inch-diameter (25.4 mm) tube; two plastic bushings; and a spring-steel tension ring fastened with a No. 10 by 1-inch-long (25.4 mm), hex washerhead, self-tapping steel screw to the bushing located in the end of the $\frac{3}{4}$ -inch-diameter (19.05 mm) tube which is inserted into the 1-inch-diameter (25.4 mm) tube. The tubes are formed from AISI 1010 steel having a minimum yield strength of 36 ksi (248 MPa). A spring-steel clip inserted into the upper end of the compression post is used with a mechanical fastener to attach the compression post to the structural roof or floor framing. A plastic clip in the opposite end of the compression post snaps onto the bulb of the main tee of the suspended ceiling. The compression post is also connected to the suspended ceiling members by wire tying the post to the hanger wires or fastening the plastic end clip to the main tee with a No. 10 by 1-inch-long (25.4 mm) bolt and hex nut. Details are noted in Table 2.

3.3 ACM7 Clip:

The clip is manufactured from 0.028-inch-thick (0.711 mm), hot-dipped galvanized, cold-rolled steel complying with ASTM A 568.

3.4 Accessories:

Each suspended ceiling system is available with a variety of wall angles, moldings, access angles and corner caps.

3.5 Materials:

3.5.1 Framing Members: Main runners and cross runners are described in Table 1 of this report, which provides the dimensions, lengths and allowable transverse loads. Main runners are classified as either Intermediate or Heavy-Duty as shown in Table 1 in accordance with ASTM C 635. The steel body of the suspension system members is hot-dipped galvanized coating Type G30 complying with ASTM A 653, except that DXFEV and ZXLA members

have a Type G60 coating prior to being painted. The exposed surface of the bottom flange of the framing members is covered with a prepainted flange capping of either steel or aluminum. The end clips of DX cross tees are high-strength, low alloy steel complying with ASTM A 568 and ASTM A 879. The end clips of the DXFEV and ZXLA cross tees are formed from Type 301 or 302 stainless steel complying with ASTM A 167.

3.5.1.1 Donn, Simplicittee and Paralinee Exposed and Concealed Ceiling Suspension Systems for Use with Acoustical Tiles: The cross tees, main tees and Paralinee metal pans are formed from steel having a minimum yield strength of 33 ksi (227.5 MPa).

3.5.1.2 Donn Drywall Suspended Ceiling Framing: The DGL-26 and DGLW-26 main runners and DGL, DGLW and DGW cross runners are formed from steel having a minimum yield strength of 30 ksi (206.8 MPa).

3.5.2 Hanger Wire: Hanger wire for suspended ceiling framing members, and fixtures, must comply with ASTM C 636 as referenced in IBC Section 808.1.1.1 (2006 IBC Section 803.9.1.1) and Section 13.5.6 of ASCE 7 as referenced in IBC Section 2506.2.1.

4.0 DESIGN AND INSTALLATION

4.1 Suspended Ceiling Framing Systems and Ceiling Systems for Acoustical Tiles:

4.1.1 General: The suspended ceiling framing system installed with acoustical tiles or the Paralinee pans must be designed and installed in accordance with Section 13.5.6 of ASCE 7 as referenced in IBC Section 1613. The minimum tension and compression capacity of framing member connections is 180 pounds (800 N).

4.1.2 Main Runners: The maximum design loads for main runners must be less than or equal to the allowable capacities noted in Table 1 of this report.

4.1.3 Cross Runners: The maximum design load for cross runners must be less than or equal to the allowable capacities shown in Table 1 of this report.

4.1.4 Seismic Design:

4.1.4.1 General: Seismic design and installation details of the ceiling system, including lighting fixtures and mechanical services, must be in accordance with Section 13.5.6 of ASCE 7 as referenced in IBC Section 1613, except as noted in Section 4.3 of this report. Systems with main runners classified as Intermediate-duty are limited to use in Seismic Design Categories A, B and C. Lighting fixtures may also be attached to the grid with clips complying with the ICC-ES Acceptance Criteria for Attachment Devices for Recessed Lighting Fixtures (Luminaires) in Suspended Ceiling Systems (AC184).

4.1.4.2 Partitions: Partitions must be laterally supported as required by Section 13.5.8 of ASCE 7, as referenced by IBC Section 1613.

4.2 Suspended Ceiling Systems for Gypsum Wallboard:

The installation must be in accordance with Section 4.1, except the ceiling must be designed for seismic loads required under Chapter 13 of ASCE 7 as referenced in IBC Section 1613. The ceiling weight must not exceed 4 psf (19.5 kg/m²). Suspended ceilings constructed of lath and plaster or gypsum boards, screw or nail attached to suspended members that support a ceiling on one level extending from wall to wall are exempt from lateral load design requirements of CISCA 3-4.

4.3 ACM7 Clip:

4.3.1 Alternate Installation for Seismic Design Categories D, E and F: With this installation, the DX main and cross runners must be main and cross runners as described in Section 3.5.1. Maximum total ceiling weight permitted is 2.5 lb/ft² (12.19 kg/m²). The ACM7 clips are used to secure the main runners and cross runners to the perimeter members (wall closures or wall moldings) on two adjacent walls and to allow free movement of the runners on the two opposing walls. See Figures 1 and 2. A nominally ⁷/₈-inch-wide (22 mm) wall closure angle (molding) is used in lieu of the 2-inch-wide (50.8 mm) perimeter wall molding required by Section 13.5.6.2.2 of ASCE 7 for Seismic Design Categories D, E and F. Except for the use of the ACM7 clips and the nominally ⁷/₈-inch-wide (22 mm) wall molding and the elimination of spacer bars, installation of the ceiling system must be as prescribed by the applicable code.

The ACM7 clip is attached to the wall molding by sliding the locking lances over the hem of the vertical leg of the wall molding. On the two adjacent walls where the runners are fixed, the clips are attached to the runner by a sheet metal screw through the clip into the bulb of the tee. On the walls where the runners are not fixed, the clips allow the terminal runner end to move ³/₄ inch (19.1 mm) towards and away from the wall. The ACM7 clips installed in this manner are used in lieu of the spacer bars (stabilizer bars) required in CISCA 3-4. CISCA 3-4 is referenced in ASCE-7, Section 13.5.6.2.2, which is referenced in IBC Section 1613.

4.3.2 Alternate Installation for Seismic Design Categories A, B and C: The ACM7 clip may be used in lieu of spacer bars (stabilizer bars) in suspended ceiling installations regulated by CISCA 0-2. The ACM7 clip is attached to the wall molding by sliding the locking lances over the hem of the vertical leg of the wall molding and using one fastener through the wall molding. The clips are placed at the intersections of all runners and the wall angle (molding). The clips must be positioned to allow a minimum ³/₈-inch (9.5 mm) movement in both directions (towards and away from the wall). The maximum ceiling weight permitted is 2.27 lb/ft² (11.06 kg/m²). See Figure 2. Except for the use of the ACM7 clip and the elimination of spacer bars (stabilizer bars), installation of the ceiling system must be as prescribed by the applicable code. This construction is equivalent to that required by CISCA 0-2, which is referenced in ASCE-7, Section 13.5.6.2.1, which in turn is referenced in IBC Section 1613.

4.4 Fire-resistance-rated Ceiling assemblies:

4.4.1 Donn (DXL) and Simplicittee (SDXL) Fire-resistance-rated Ceiling Systems:

4.4.1.1 Two-hour Fire-resistance-rated Exposed Floor-ceiling System: The DXL and SDXL systems consist of a bulb tee with ¹⁵/₁₆-inch-wide (23.8 mm) lower flange and main and cross-tee sizes shown in Table 1. The main tees are spaced 4 feet (1219 mm) on center and the cross tees 2 feet (610 mm) on center. The main tees are supported 48 inches (1219 mm) on center with No. 12 gage galvanized steel wires. Additionally, the same wires support the four corners of light fixtures and the center of each cross tee adjacent to the fixtures and air outlet ducts. The structural framing system consists of a minimum W8 × 15 steel beam that supports a minimum No. 18 gage, 1¹/₂-inch-deep (38.1 mm) steel deck with flutes spaced 6 inches (152.4 mm) on center. The deck is welded to supports at 12 inches (604.8 mm) on center with welded or button-punched seams spaced 36 inches (914.4 mm) on

center. Cellular steel decks may also be used. The decks are covered with normal-weight concrete having a minimum compressive strength of 3,500 psi (24.13 MPa) to a thickness of $2\frac{1}{2}$ inches (63.5 mm) over the top flute. Approved, recessed, 2-foot-by-4-foot (610 mm by 1219 mm) light fixtures may be used in the ceiling when spaced at up to 16 square feet per 100 square feet of ceiling area. The light fixtures must be independently supported by hanger wires. Approved air duct openings with approved dampers with a maximum opening dimension of 12 inches (305 mm) may be used in the ceiling, provided they are spaced at up to 113 square inches per 100 square feet of ceiling area. The lay-in acoustical material is USG Interiors, LLC, $\frac{5}{8}$ -inch-thick (15.8 mm), Type FR-83 nonperforated tile. The acoustical material is also used for protection of recessed light fixtures and consists of a three-sided enclosure cut to provide a 1-inch (25.4 mm) clearance around the fixture. The pieces are held together with three 6d nails on each side. Light fixtures located below or adjacent to a beam must have an additional piece of acoustical material laid on top of the enclosure. Hold-down clips spaced 2 feet (610 mm) on center are used to anchor the acoustical material weighing less than 1 psf (4.9 kg/m²). The overall assembly depth is $24\frac{3}{8}$ inches (619 mm). The restrained and unrestrained rating of the assembly is two hours. The unrestrained beam rating is four hours. See Table 1 for allowable loads.

4.4.1.2 One-hour Fire-resistance-rated Exposed Roof-ceiling System: The DXL and SDXL systems consist of a bulb tee with $\frac{15}{16}$ -inch-wide (23.8 mm) lower flange and main and cross-tee sizes as shown in Table 1. The main tees are spaced 4 feet (1219 mm) on center and the cross tees 2 feet (610 mm) on center. The main tees are supported 4 feet (1219 mm) on center with No. 12 gage galvanized steel wires. Additionally, the same size wires support the framing members at the four corners of light fixtures and the center of each cross tee adjacent to the fixtures and air outlet ducts. Approved, recessed, 2-foot-by-4-foot (610 mm by 1219 mm) light fixtures may be used in the ceiling when spaced at up to 24 square feet per 100 square feet of ceiling area. The light fixtures must be independently supported by hanger wires. Approved air duct openings with approved dampers may be used in ceilings that have a maximum opening dimension of 30 inches (762 mm), and these are spaced at up to 576 square inches (0.371 m²) per 100 square feet (9.25 m²) of ceiling area for steel ducts. The lay-in acoustical material is USG Interiors, LLC, $\frac{5}{8}$ -inch-thick (15.8 mm), Type FR-83 ceiling panels tile. The acoustical material is also used for protection of recessed light fixtures and consists of a three-sided rectangular enclosure cut to provide a 1-inch (25.4 mm) clearance around the fixture. The pieces are held together with three 6d nails on each side. Light fixtures located below or adjacent to a beam must have an additional piece of acoustical material laid on top of the enclosure. The overall assembly depth is 24 inches (50.8 mm). The restrained and unrestrained assembly rating is one hour. The roof consists of minimum No. 22 gage (0.020 inch thick), 1-inch-deep (25.4 mm), galvanized steel deck, with 1-inch-wide (25.4 mm) flutes at $3\frac{1}{2}$ inches (89 mm) on center. Steel joists, 10 inches (254 mm) deep, are spaced 48 inches (1219 mm) on center. Decking is secured to the joists with $\frac{1}{2}$ -inch-diameter (12.7 mm) puddle welds through weld washers at 12 inches (305 mm) on center. United States Gypsum Company Type SCX gypsum wallboard, 4 feet (1219 mm) wide and $\frac{5}{8}$ inch (15.8 mm) thick, is placed with the long dimension perpendicular to the deck. Board end joints must be staggered a minimum of 1 foot (304.8 mm) from adjacent courses. A layer of vinyl vapor barrier is laminated over the

wallboard. One or more layers of mineral and fiber insulation boards comprise the roof insulation. The boards are a minimum of 24 inches by 48 inches (610 mm by 1219 mm) by 1 inch (25.4 mm) thick. The first layer is placed perpendicular to the gypsum sheathing with end joints staggered a minimum of 2 feet (610 mm) from adjacent courses. Subsequent insulation board layers must have all joints staggered from adjacent layers a minimum of 12 inches (305 mm). The first two layers are secured through the gypsum sheathing into the decking with mechanical fasteners. Additional insulation board layers are adhered with hot asphalt or coal tar pitch at a rate not exceeding 25 pounds (11.3 kg) per square. A Class A, B or C built-up roof covering is applied over the insulation. The suspended ceiling grid system is hung by No. 12 gage galvanized steel wires, 48 inches (1219 mm) on center, tied to main runners and bottom chord of joists. The ceiling must be suspended a minimum of 24 inches (610 mm) below the bottom of the roof deck and a minimum of 12 inches (305 mm) below joists.

4.4.1.3 One-hour Fire-resistance-rated Concealed Floor-ceiling Systems: These systems support an approved $\frac{3}{4}$ -inch-thick (19.05 mm), 12-inch (305 mm) square nonventilating acoustical mineral tile with kerfed edges. Hold-down clips are used for each tile around the perimeter. The galvanized steel DXL24 or SDXL24 main tee and DXL424 or SDXL424 cross-tee framing members support 2-foot-by-4-foot (610 mm-by-1219 mm) approved recessed light fixtures having slotted air openings on each side for $34\frac{1}{2}$ -inch-long-by- $1\frac{1}{4}$ -inch-wide (876 mm by 31.7 mm) air boots. All air boots are provided with approved fire dampers. The stabilizer bars oppose the cross tees that support the long edge of the light fixtures, and are connected to the main tee. Light fixture framing members are supported at each corner of the fixture and at midspan of the cross tees along the long edge of the fixture. The light fixtures must be independently supported by hanger wires. Hanger wires are No. 12 gage galvanized steel. All main runners are supported with the hanger wires at 48 inches (1219 mm) on center, except at light fixtures where the supports are at the fixture corners. For additional support and installation details, see Figure 3. All light fixtures are protected above by a rectangular-shaped box consisting of $\frac{5}{8}$ -inch-thick (15.8 mm), approved mineral fiber board. Each side of the box is fastened to the top with four 7d coated nails. The structural framing system consists of open web steel joists spaced at 24 inches (610 mm) on center and supported by steel beams. The top and bottom of the joists are braced with $\frac{1}{2}$ -inch-diameter (12.7 mm) steel bars spaced at 7 feet (2.1 m) on center and welded to each joist. Expanded 3.4 lb/yd² (1.8 kg/m²), $\frac{3}{8}$ -inch (9.52 mm) ribbed metal lath is placed over the joists with ribs transverse to the joists. Normal-weight concrete with a 28-day compressive strength of 3,000 psi and an average thickness of $2\frac{3}{4}$ inches (70 mm) is placed over the metal lath. The entire assembly is $21\frac{1}{2}$ inches (546 mm) deep, including the ceiling and concrete.

The approved light fixtures may occupy a maximum of 16 square feet (1.48 m²) per 100 square feet (9.25 m²) of ceiling area. See Table 1 for allowable loads.

4.4.2 Paraline™ (DXLP) Linear Metal Ceiling Systems in Two-hour and Three-hour Restrained or Unrestrained Floor-ceiling Systems: The Paraline™ (DXLP) linear metal ceiling system is a suspended ceiling consisting of $3\frac{1}{4}$ -inch-wide (82 mm), channel-shaped Paraline pans of 0.015-inch to 0.021-inch (0.381 mm to 0.530 mm) steel or 0.018-inch to 0.024-inch (0.45 mm to 0.60 mm) aluminum that are snap-locked to the bottom of

DXP or DXLP Paralok main tees. The system may be used as two-hour or three-hour fire-resistance-rated assembly as described below. See Table 1 for allowable loads.

The ceiling system consists of the DXLP 1¹/₂-inch-deep (38.1 mm), bulb-shaped steel main tees spaced at 48 inches (1219 mm) on center with 1¹/₂-inch-deep (38.1 mm), DXL steel cross tees spaced at 24 inches (610 mm) on center, suspended by No. 12 gage galvanized steel hanger wires, 19 inches (482.6 mm) below minimum No. 20 gage fluted, or No. 22/22 gage cellular, 1¹/₂-inch-deep (38.1 mm) steel decks. The decks must have 3¹/₂-inch-wide (89 mm) flutes spaced at 6 inches (152.4 mm) on center. Allowable loading on the steel decks must be based on noncomposite design. When the deck is covered with 2¹/₂-inch-thick (63.5 mm), 4,500 psi (31 MPa), normal-weight concrete, the assembly has a two-hour fire-resistive rating, and, with 3¹/₄-inch-thick (82.5 mm) concrete, a three-hour fire rating. The steel decks are supported by minimum W8 × 15 steel beams. The hanger wires are spaced a maximum of 48 inches (1219 mm) on center along each main runner adjacent to the intersection with cross tees; at the four corners of grid framing modules containing light fixtures and/or air boots; the main runners, at all four corners of air boots; at the center of all cross tees located adjacent to and parallel with walls; and within 6 inches (152.4 mm) of each main runner splice location. The following light fixtures may be used individually or mixed:

1. Nominally 24-inch-by-48-inch (610 mm by 1219 mm) fixtures spaced so that the area does not exceed 20 square feet (1.85 m²) per 100 square feet (9.25 m²) of ceiling area.
2. Nominally 9-inch-by-48-inch (228.6 mm by 1219 mm) fixtures spaced so that the number of fixtures does not exceed nine per 200 square feet (18.6 m²) of ceiling area.
3. Nominally 5-inch-by-48-inch (127 mm by 1219 mm) fixtures spaced so that the number of fixtures does not exceed six per 100 square feet (9.25 m²) of ceiling area.

Nominally 4-foot-long (1219 mm) Donn Paralok air boots with 6-inch-diameter (152.4 mm) inlets may also be used in the system. Spacing of air boots must not exceed one per 100 square feet (9.25 m²) of ceiling area.

All light fixtures must be completely enclosed with 5/8-inch-thick (15.8 mm), Type FR-83 (s) acoustical boards manufactured by USG Interiors, LLC, that are held together with three 6d nails on each side. The same acoustical board, 24 inches by 48 inches (610 mm by 1219 mm), is laid in between all cross tees and main runners.

Hold-down clips are placed over the cross tees symmetrically at 2 feet (610 mm) on center when the acoustical material weighs less than 1 psf (4.9 kg/m²). Access clips may be used in lieu of hold-down clips, where required.

The Paralok plain or perforated metal pans Types PSS, PSR, PSSP and PSRP (steel units) may be used for the two-hour or three-hour fire ratings. The Types PAR, PASP and PARP (aluminum pans) are for use only with the two-hour fire rating.

4.4.3 Donn Fineline (DXLF) Ceiling Suspension System:

4.4.3.1 One-hour Fire-resistance-rated Floor-ceiling System: The Donn Fineline suspension system is designed to support acoustical panels in one-hour fire-

resistive floor-ceiling assemblies as noted in Figure 4. The main runners, 4-foot-long (1219 mm) cross tees and 2-foot-long (610 mm) cross tees are designated DXLF-29, DXLF-429 and DXLF-229, respectively. The overall depths and thicknesses of the runners and cross tees are described in Table 1.

4.4.3.2 One-hour Fire-resistance-rated Roof-ceiling System:

The same framing members described in Section 4.4.3.1 of this report may be used as part of a one-hour fire-resistive, restrained, roof-ceiling assembly that may be described as follows: The main runners are spaced 4 feet (1219 mm) on center. Cross tees, 4 feet (1219 mm) long, are spaced 2 feet (610 mm) on center and inserted into main runners. Cross tees 2 feet (610 mm) long are inserted perpendicular to the 4-foot (1219 mm) cross tees and spaced to provide 24-inch-by-24-inch (610 mm by 610 mm) modules. Ceiling panels are USG Interiors, LLC, GR-1(s) perforated, with dimensions of 24 inches by 24 inches by 3/4 inch thick (610 by 610 by 19.05 mm). Panels at walls are supported by No. 26 gage steel angles with 1³/₁₆-inch (30.16 mm) and 5/8-inch (15.8 mm) legs.

The roof consists of minimum No. 22 gage, 1¹/₂-inch-deep (38.1 mm), galvanized steel deck, with flutes at 6 inches (152.4 mm) on center. Steel joists, 10 inches (254 mm) deep, are spaced 48 inches (1219 mm) on center. Decking is secured to the joists with 1/2-inch-diameter (12.7 mm) puddle welds through weld washers at 12 inches (305 mm) on center. Water-resistant core gypsum sheathing complying with ASTM C 1396, 4 feet (1219 mm) wide and 5/8 inch (15.8 mm) thick, is placed with the long dimension perpendicular to the deck.

Board end joints must be staggered a minimum of 1 foot (305 mm) from adjacent courses. Optional mineral and fiber insulation boards manufactured by Manville comprise the roof insulation. The boards are a minimum of 24 inches by 48 inches by 1 inch thick (610 by 1219 by 25.4 mm). The first layer is placed perpendicular to the gypsum sheathing with end joints staggered a minimum of 2 feet (610 mm) from adjacent courses. Subsequent insulation board layers must have all joints staggered from adjacent layers a minimum of 12 inches (305 mm). The first two layers are secured through the gypsum sheathing into the decking with 3/4-inch-long (82.55 mm) screws having 0.203-inch-diameter (5.15 mm) shanks. The screws have a special tip that locks against the steel deck underside. The screws are placed through 2¹/₈-inch-diameter (54 mm), 0.030-inch-thick (0.76 mm) steel discs at each board corner. Additional insulation board layers are adhered with hot asphalt or coal-tar pitch at a rate not exceeding 25 pounds per square. A Class A, B or C built-up roof covering is applied over the insulation. The suspended ceiling framing system is hung by No. 12 gage galvanized steel wires, 48 inches (1219 mm) on center, tied to main runners and bottom chord joists. The soffit of the ceiling must be suspended a minimum of 20 inches (508 mm) below the bottom of the roof deck and a minimum of 10 inches (254 mm) below joists.

4.4.4 Donn Centricitee (DXLT) One-hour Fire-resistance-rated System:

The Donn DXLT Centricitee exposed grid system is designed to support lay-in acoustical panels in a one-hour fire-resistive floor-ceiling assembly. See Figure 4 for a description. The main runners, 4-foot-long (1219 mm) cross tees and 2-foot-long (610 mm) cross tees are designated as DXLT-24, DXLT-424, DXLT-218 and DXLT-222, respectively. The overall depths and thicknesses of the runners and cross tees are described in Table 1.

4.4.5 Donn Drywall Suspended Fire-resistance-rated Ceiling Systems: The USG Donn drywall suspension systems are concealed, direct-hung grid systems that can be utilized as part of a fire-resistive floor-ceiling assembly as shown in Figure 5, with ratings as listed in Table 3. The main runners are either Type DGL or DGLW main runners. The cross runners are either Type DGCL or Type DGLW cross runners, except that Type DGL cross runners are used around recessed light fixtures.

The ratings apply to restrained and unrestrained assemblies as described in ASTM E 119, which is referenced in IBC Section 703. General requirements of Section 712.1 of the 2009 IBC (2006 IBC section 711.1) must be observed.

4.5 Special Inspection:

Suspended ceilings in Seismic Design Categories D, E and F shall be subject to periodic special inspections during the installation of the suspended ceiling systems and their anchorage, in accordance with the requirements of IBC Section 2506.2.1, Section 13.5.6.2.2 (h) of ASCE 7, and 2009 IBC Section 1705.3.4, Item 3 (2006 IBC Section 1705.3, Item 4.3). The special inspector must verify that the ceiling system is as described in this report, and complies with the installation instructions in this report, and with the approved construction documents.

5.0 CONDITIONS OF USE

The USG suspended ceiling framing systems described in this report comply with, or are suitable alternatives to what is specified in, those codes listed in Section 1.0 of this report, subject to the following conditions:

- 5.1 The ceiling suspension main runners, cross runners, ACM7 clips and seismic compression post are fabricated and installed in accordance with this report and the manufacturer's published installation instructions. In the event of a conflict between the manufacturer's installation instructions and this report, this report governs.
- 5.2 Design loads and spans of main and cross runners must comply with Table 1 of this report.
- 5.3 Suspended ceiling systems must be designed in accordance with ASCE 7, Section 13.5.6, as referenced by IBC section 1613. The documents must be prepared by a registered design professional where required by statutes of the jurisdiction in which the project is to be constructed.
- 5.4 For Seismic Design Category C, D, E or F, a quality assurance plan complying with IBC Chapter 17, including Sections 1705.2 and 1705.3, must be submitted to the code official.

5.5 Periodic special inspections must be provided in accordance with Section 4.5 of this report. A statement of special inspection must be provided as required in 2009 IBC Section 1705.3.4, Item 3 (2006 IBC Section 1705.3, Item 4.3).

5.6 The ceiling framing systems must not be used to provide lateral support for walls or partitions, except as provided for in ASCE 7, Section 13.5.8.1, as referenced in IBC Section 1613.

5.7 The ceiling systems must be braced to resist seismic forces as determined from Section 1613 of the IBC.

5.8 The supporting construction for the ceiling system has not been evaluated and is outside the scope of this report. The code official must approve the floor or roof construction supporting the suspended ceiling system.

5.9 The ceiling systems are limited to ceilings not considered accessible in accordance with Item 31 of 2009 IBC Table 1607.1 (Item 32 of 2006 IBC Table 1607.1).

5.10 The ceiling systems are limited to interior application. For exterior ceiling installations, the ceiling systems must be designed for wind loads and with due consideration of atmospheric conditions.

5.11 Lay-in ceiling panels must be justified to the satisfaction of the code official as complying with the interior finish requirements of Chapter 8 of the applicable code.

5.12 Lighting fixtures and mechanical services must be as described in Section 4.1.4.

6.0 EVIDENCE SUBMITTED

- 6.1 Data in accordance with the ICC-ES Acceptance Criteria for Suspended Ceiling Framing Systems (AC368), dated February 2007 (editorially revised April 2011).
- 6.2 Data in accordance with the ICC-ES Acceptance Criteria for Seismic Certification by Shake-table Testing of Nonstructural Components (AC156), dated October 2010.
- 6.3 Reports of fire-resistance tests in accordance with ASTM E 119.

7.0 IDENTIFICATION

Cartons of framing members, ACM7 clips, seismic compression posts and accessories are identified with the name and address of USG Interiors, LLC, the manufacturing location, the framing member designations and the evaluation report number (ESR-1222).

TABLE 1—DIMENSIONS AND ALLOWABLE LOADS FOR FRAMING MEMBERS

Item Number		Part Number	Member	Load Classification	Length of Member (inches) nominal	Height of Member (inches)	Metal Thickness (inches)	Maximum Span (inches)	Maximum Spacing (inches)	Ceiling Load (pounds per square foot)	Simple Span (pounds per lineal foot)	Required Lateral Support (inches on center)
DONN® Brand & Simplicitee Exposed and Concealed Ceiling Suspension Systems												
1	1	DX-24 SDX-24	Main Tee	Intermediate Duty	144	1.64	0.014	48	48	3	12	24
1a	1	DX-140	Main Tee	Intermediate Duty	140	1.64	0.014	48	48	3	12	24
1b*	1	DXL-24 DXL-24	Main Tee	Intermediate Duty	144	1.64	0.014	48	48	3	12	24
2	2	DX-26	Main Tee	Heavy Duty	144	1.64	0.016	48	48	4	16	24
2a*	2	DXL-26	Main Tee	Heavy Duty	144	1.64	0.016	48	48	4	16	24
3	3	DX-216 SDX-216	Cross Tee		24	1.00	0.01	24	60	2.9	14.8	
3a*	3	DXL-216 SDXL-216	Cross Tee		24	1.00	0.014	24	24	13.7	27.3	
4		DXD-216	Cross Tee		24	1.00	0.01	24	60	2.9	14.8	
5		DX-20	Cross Tee		20	1.00	0.01	20	60	5.3	26.5	20
6		DX-30	Cross Tee		30	1.00	0.014	30	60	2.7	13.6	30
7		DXD-316	Cross Tee		36	1.00	0.01	36	36	2.6	7.7	36
8		DX-316	Cross Tee		36	1.00	0.01	36	36	2.6	7.7	36
9*		DXL 324	Cross Tee		36	1.50	0.014	36	36	2.6	7.7	36
10		DX-416 SDX-416	Cross Tee		48	1.00	0.014	48	48	1	4.2	
11		DXD-416	Cross Tee		48	1.00	0.014	48	48	1	4.2	
12		DX-422 SDX-422	Cross Tee		48	1.50	0.01	48	48	2.3	9.1	
13	4	DX-424 SDX-424	Cross Tee		48	1.50	0.014	48	48	3	12	
13a*	4	DXL-424 SDXL-424	Cross Tee		48	1.50	0.014	48	48	3	12	
14		DX-426	Cross Tee		48	1.50	0.022	48	48	4	16	
15		DX-522	Cross Tee		60	1.50	0.01	60	24	2.1	4.3	60
16	5	DX-524	Cross Tee		60	1.50	0.014	60	24	3.5	7.15	60
16a*	5	DXL-524	Cross Tee		60	1.50	0.014	60	24	3.5	7.15	60
17		DX-526	Cross Tee		60	1.50	0.021	60	60	1.8	9.3	60
DONN® Brand Exposed Ceiling Suspension Systems with Aluminum Cap or Environmental												
18*		DXLA-24	Main Tee	Intermediate Duty	144	1.64	0.014	48	48	3	12	24
19*		DXLA26	Main Tee	Heavy Duty	144	1.64	0.016	48	48	4	16	24
20*		DXLA-216	Cross Tee		24	1.00	0.01	24	24	12.5	25	24
21*		DXLA-424	Cross Tee		48	1.50	0.014	48	48	3	12	
22*		ZXLA-24	Main Tee	Intermediate Duty	144	1.64	0.014	48	48	3	12	24
23*		ZXLA-26	Main Tee	Heavy Duty	144	1.64	0.016	48	48	4	16	24
24*		ZXLA-224	Cross Tee		24	1.50	0.014	24	24	15	30	
25*		ZXLA 524	Cross Tee		60	1.50	0.014	60	24	3.5	7.15	60
26*		ZXLA 424	Cross Tee		48	1.50	0.014	48	48	3	12	
PARALINE™ Brand Linear Metal Ceiling Suspension System												
27	6	DXP	Main Tee	Heavy Duty	144	1.50	0.02	48	24	3	12	24
27a*	6	DXLP	Main Tee	Heavy Duty	145	1.51	0.02	48	24	3	12	24
FINELINE® Brand Exposed Ceiling Suspension Systems												
28		DXFF-29	Main Tee	Intermediate Duty	144	1.80	0.015	48	48	3	12	24
29		DXFFH-29	Main Tee	Heavy Duty	144	1.80	0.015	48	48	4	16	24
30		DXFF-229	Cross Tee		24	1.80	0.015	24	60	10	50	24
31		DXFF-429N	Cross Tee		48	1.80	0.015	48	48	3	12	48
32		DXFF-529N	Cross Tee		60	1.80	0.015	60	60	1.4	7.2	30
33		DXF-29	Main Tee	Intermediate Duty	144	1.80	0.016	48	60	2.4	12	24
34		DXFH-29	Main Tee	Heavy Duty	144	1.80	0.015	48	60	3.3	16	24
35	7	DXF-129	Cross Tee		12	1.80	0.016	12	60	10	50	12
36	7	DXF-20	Cross Tee		20	1.80	0.015	20	60	10	50	20
37	7	DXF-229	Cross Tee		24	1.80	0.015	24	60	10	50	24
38	7	DXF-30	Cross Tee		30	1.80	0.015	30	60	6.7	33.6	30
39	7	DXF-329	Cross Tee		36	1.80	0.015	36	36	7.3	22	18
40	7	DXF-429N	Cross Tee		48	1.80	0.015	48	48	3	12	24
41	7	DXF-529N	Cross Tee		60	1.80	0.015	60	24	3.4	6.9	30
42*	7	DXLF-29	Main Tee	Intermediate Duty	144	1.80	0.016	48	48	3	12	24
43*	7	DXLF-229	Cross Tee		24	1.80	0.015	24	60	10	50	24
44*	7	DXLF-429N	Cross Tee		48	1.80	0.015	48	48	3	12	24

TABLE 1—DIMENSIONS AND ALLOWABLE LOADS FOR FRAMING MEMBERS (Continued)

Item Number	Part Number	Member	Load Classification	Length of Member (inches) nominal	Height of Member (inches)	Metal Thickness (inches)	Maximum Span (inches)	Maximum Spacing (inches)	Ceiling Load (pounds per square foot)	Simple Span (pounds per lineal foot)	Required Lateral Support (inches on center)	
CENTRICITEE® Brand Exposed Ceiling Suspension Systems												
45	DXT-24	Main Tee	Intermediate Duty	144	1.50	0.016	48	48	3	12	24	
46*	DXLT-24	Main Tee	Intermediate Duty	144	1.50	0.018	48	48	3	12	24	
47	DXT-26	Main Tee	Heavy Duty	144	1.50	0.024	48	48	4	16	24	
48	DXT-524	Cross Tee		60	1.50	0.016	60	60	1.3	6.7	30	
49	⁸ DXT-424	Cross Tee		48	1.50	0.016	48	48	3	12	24	
49a*	⁸ DXLT-424	Cross Tee		48	1.50	0.016	48	48	3	12	24	
50	DXT-418	Cross Tee		48	1.13	0.014	48	48	0.8	3.3	48	
51	DXT-422	Cross Tee		48	1.50	0.01	48	48	0.9	3.8	48	
52	⁹ DXT-218	Cross Tee		24	1.13	0.014	24	24	7.8	15.6	24	
52a*	⁹ DXLT-218	Cross Tee		24	1.13	0.014	24	24	7.8	15.6	24	
53	¹⁰ DXT-222	Cross Tee		24	1.50	0.01	24	24	10	20.5	24	
53a*	¹⁰ DXLT-222	Cross Tee		24	1.50	0.01	24	24	10	20.5	24	
MERIDIAN® Brand Exposed Ceiling Suspension Systems												
54	DXM-24	Main Tee	Intermediate Duty	144	1.50	0.02	48	48	3	12	24	
55	DXM-224	Cross Tee		24	1.50	0.017	24	24	25	50	24	
56	DXM-424	Cross Tee		48	1.50	0.017	48	48	2.6	10.3	48	
57	DXM-524	Cross Tee		60	1.50	0.017	60	24	2.7	5.4	60	
DONN® Brand Drywall Suspended Ceiling System												
58*	DGL 26	Main Tee	Heavy Duty	144	1.62	0.018	48	72	4	16		
59*	DGLW 26	Main Tee	Heavy Duty	144	1.62	0.018	48	72	4	16		
60*	DGLW 26s	Main Tee	Heavy Duty	72 - 168	1.62	0.018	48	24	4	16		
66*	DGL 224	Cross Tee		24	1.50	0.016	24	24		81.3		
67*	DGL 424	Cross Tee		48	1.50	0.016	48	48		13		
68	DGW 624	Cross Tee		72	1.50	0.014	72	48		4.45		
69*	DGLW 224	Cross Tee		24	1.50	0.014	24	24		73.2		
70*	DGLW 2624	Cross Tee		26	1.50	0.014	26	24		57		
71*	DGLW 424	Cross Tee		48	1.50	0.014	48	48		12.1		
72*	DGLW 50	Cross Tee		50	1.50	0.014	50	24		11		
73*	DGCL 4	Cross Channel		48	0.88	0.019	48	24		6.9		
DONN® Brand Non-Rated Exposed Suspended Ceiling Systems												
71	DXW 26	Main Tee	Heavy Duty	144	1.50	0.019	48	48	4.4	17.1	24	
72	DXW 224	Cross Tee		24	1.50	0.013	24	24	18.3	36.7	24	
73	DXW 424	Cross Tee		48	1.50	0.013	48	48	3.3	13.4	48	
74	DXCE-24	Main Tee	Intermediate Duty	144	1.64	0.014	48	48	3	12	24	
75	DXCE-224	Cross Tee		24	1.50	0.014	24	24	15	30	N/A	
76	DXCE-424	Cross Tee		48	1.50	0.014	48	48	3	12	N/A	
77	DXWCE 26	Main Tee	Heavy Duty	144	1.50	0.019	48	48	4.4	17.1	24	
78	DXWCE 224	Cross Tee		24	1.50	0.013	24	24	18.3	36.7	24	
79	DXWCE 424	Cross Tee		48	1.50	0.013	48	48	3.3	13.4	48	

For SI: 1 inch = 25.4 mm; 1 psf = 48 N/m², 1 plf = 14.6 N/m.

1	Items 1 & 1b will be sold as DX/DXL 24 & SDX/SDXL 24
2	Items 2 & 2a will be sold as DX/DXL 26
3	Items 3 & 3a will be sold as DX/DXL 216 & SDX/SDXL 216
4	Items 13 & 13a will be sold as DX/DXL 424 & SDX/SDXL 424
5	Items 16 & 16a will be sold as DX/DXL 524
6	Items 27 & 27a will be sold as DXP/DXLP 26
7	Items 35 -44 can also be found as DXFEV with a galvanization Type G60
8	Items 49 & 49a will be sold as DXT/DXLT 424
9	Items 52 & 52a will be sold as DXT/DXLT 218
10	Items 53 & 53a will be sold as DXT/DXLT 222
*	Fire-Resistant-Rated

TABLE 2—DONN COMPRESSION POST

TYPE	TUBE LENGTHS (inches)		OVERALL COMPRESSION POST LENGTH (inches)	
	1-inch Diameter	3/4-inch Diameter	Minimum	Maximum
VSA 18/30	17	17	18	30
VSA 30/48	24	30	30	48
VSA 48/84	48	40	48	84
VSA 84/102	72	40	84	102

For SI: 1 inch = 25.4 mm.

TABLE 3—FIRE-RESISTANCE-RATED ASSEMBLIES

RESTRAINED OR UNRESTRAINED ASSEMBLY RATING (hours)	UNRESTRAINED BEAM RATING (hours)	CONCRETE THICKNESS (inches)	WALLBOARD THICKNESS (inch)
2	3	2 ¹ / ₂	1/2
3	3	3 ¹ / ₄	1/2
3	3	2 ³ / ₄	5/8

For SI: 1 inch = 25.4 mm.

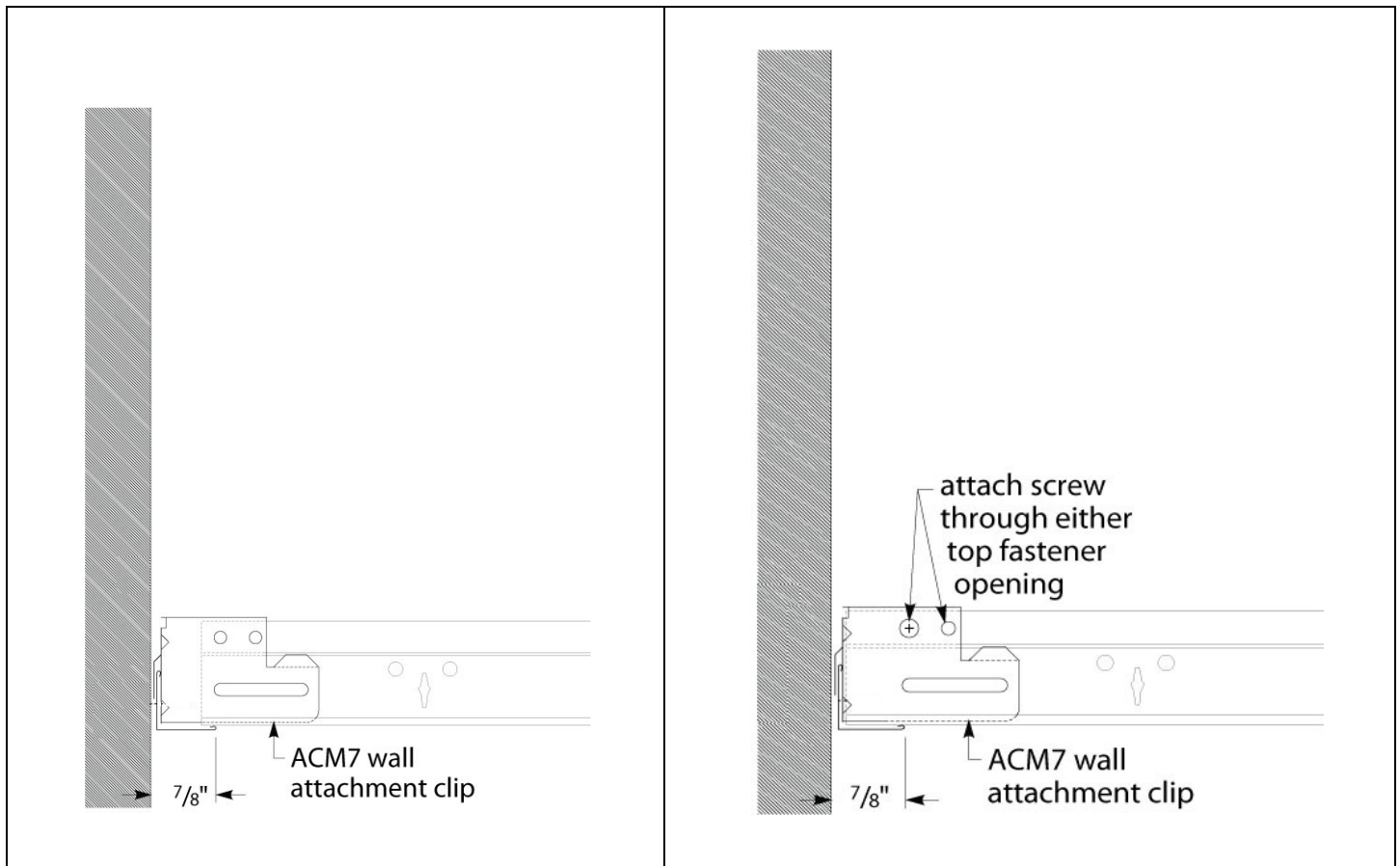

FIGURE 1—ACM7 CLIP UNRESTRAINED

FIGURE 2—ACM7 CLIP RESTRAINED

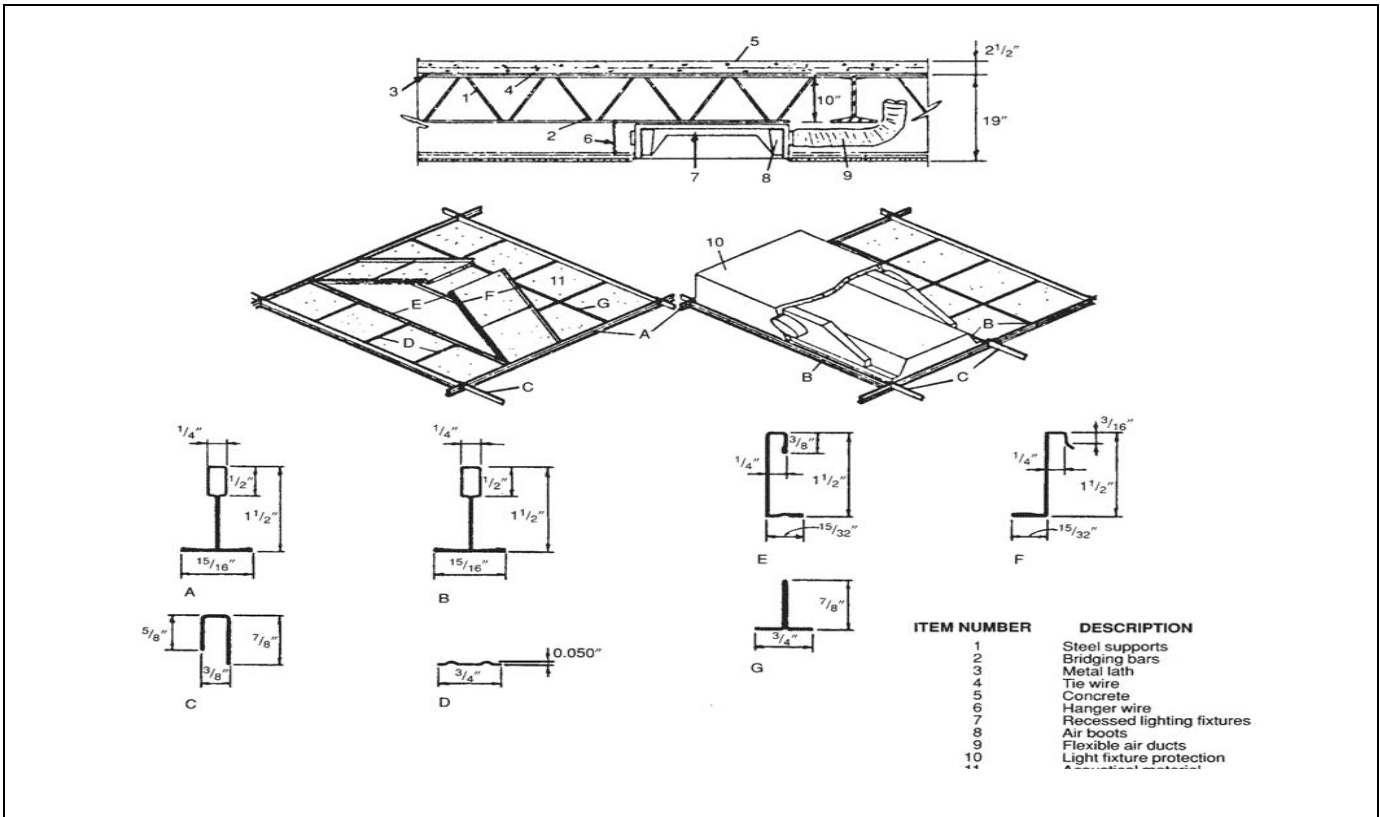
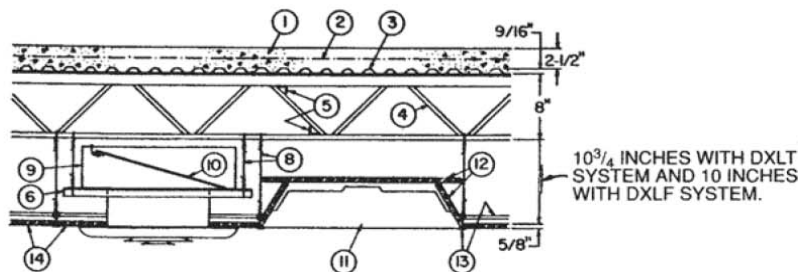
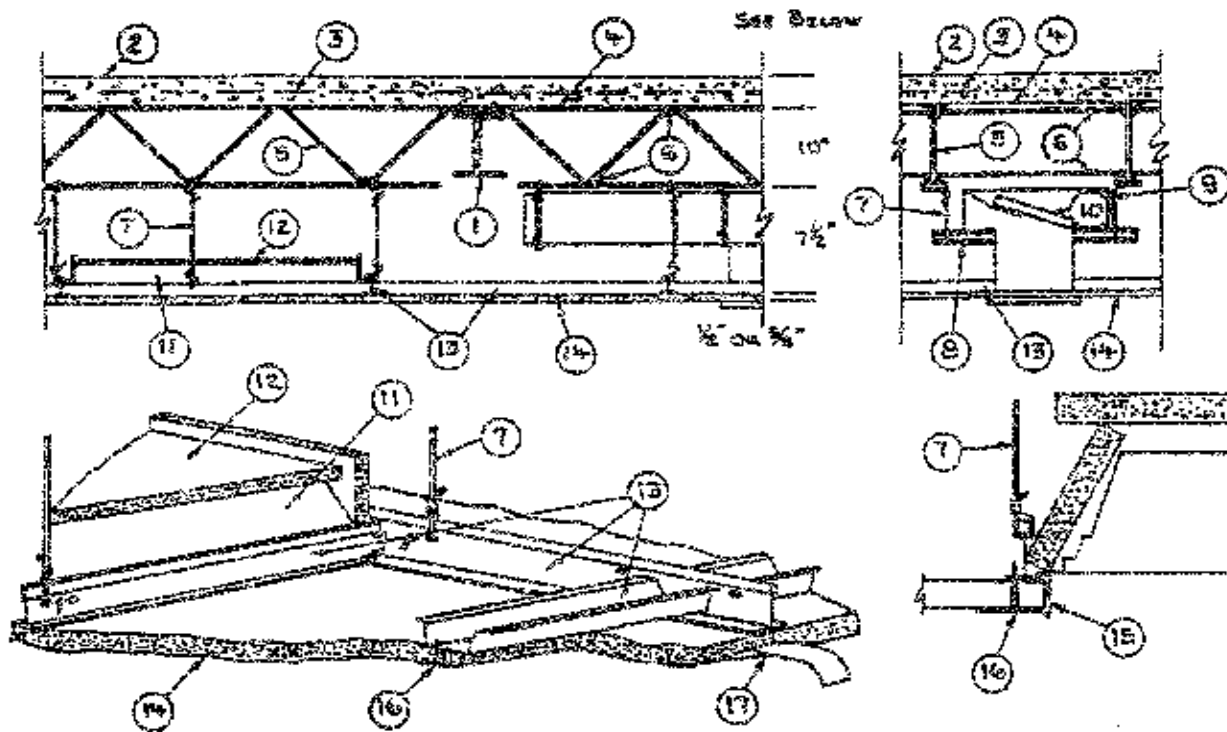

FIGURE 3—DONN DXL ONE-HOUR FIRE-RESISTANT-RATED AND CONCEALED CEILING SYSTEMS



- Normal-weight Concrete.** Carbonate or siliceous aggregate, 150 ± 3-pcf unit weight, 3,500-psi compressive strength with DXLT system and 2,500 psi with DXLF system.
- Welded Wire Fabric.** 6 x 6-W1.4 x W1.4 or heavier.
- Steel Form Units.** Minimum 9/16-inch-deep corrugated unites of minimum No. 24 MSG galvanized steel, welded to supports with 1/2-inch puddle welds through welding washers. Welds located at each joist. Adjacent units overlapped one corrugation at the sides.
- Steel Joists.** Type 8H3 minimum size; spaced 24 inches on center, welded to end supports.
- Bridging.** One by 1-inch steel angles, welded to top and bottom chord of each joist.
- Duct Supports.** Nominal 1 by 1 by 1/8-inch-thick steel angles or No. 16 MSG cold-rolled steel channels, 1 1/2 inches deep, suspended from lower chord of joists with No. 12 SWG galvanized steel wire to form a trapeze. Duct supports must be spaced at 48 inches on center maximum along length of duct and at air duct outlets.
- Cold-rolled Channels.** (Not shown)—No. 16 MSG cold-rolled steel channels, 1 1/2 inches deep with 9/16-inch flanges, located as needed to provide means of attachment for hanger wires located away from steel joists. Placed on top and secured to lower chord of joists with No. 18 SWG galvanized steel wire.
- Hanger Wire.** No. 12 SWG galvanized steel wire, twist-tied to lower chord of joists, spaced not over 48 inches on center along main runners adjacent to cross-tee intersections. If not already present, hanger wires shall also be provided at the four corners of light fixtures, at center of cross tees supporting the long sides of light fixtures and at center of cross tees adjacent to air duct outlets.
- Air Duct.** No. 22 MSG minimum galvanized steel. Total area of duct openings not to exceed 113 square inches per each 100 square feet of ceiling area. Area of individual duct opening not to exceed 113 square inches. Maximum dimension of opening 12 inches.
- Damper.** No. 16 MSG galvanized steel, sized to overlap duct opening 1 inch minimum. Protected on both surfaces with 1/16-inch-thick ceramic fiber paper and held open with a fusible link.
- Fixtures, Recessed Light.** Fluorescent lamp-type, steel housing, 2 by 4 foot size with DXLT system and 2 by 2 foot size with DXLF system. Fixtures spaced so their area does not exceed 24 square feet per each 100 square feet of ceiling area. Wired in conformance with the National Electrical Code.
- Fixture Protection—Acoustical Materials.** 5/8-inch-thick USG Acoustical Products Co. GR-1(s) tiles having surface perforations cut into pieces to form a three-sided enclosure with open ends and trapezoidal in cross-section. Fixture protection consists of a 23 3/4-by-47 3/4-inch top piece, with DXLT system and 23 3/4-by-23 3/4-inch top piece with DXLF system, two side pieces of a width which will provide a minimum 5/8 inch clearance between top piece and the fixture housing and are 47 3/4 and 23 3/4 inches long for the DXLT and DXLF systems, respectively. The side pieces are placed against the sides of the fixture and the top piece is placed on top of the side pieces. The pieces are held together by 6d nails near the center and near the ends on each long side of the fixture.
- Steel Framing Members.** DXLT or DXLF main runners, nominal 12 feet long spaced 4 feet on center. Cross tees, nominal 4 feet long installed perpendicular to main runners and spaced 2 feet on center. Cross tees, nominal 2 feet long, installed perpendicular to the 4-foot cross tees and spaced 2 feet on center.
- Acoustical Material.** Nominal 24 by 24 by 5/8-inch-thick USG Acoustical Products Co. GR-1(s) or GR-2(s). Border panels supported at walls by No. 26 MSG painted steel angles with 3/4-inch and 1-inch legs or channels 1 5/8 inches deep with 1-inch bottom and 3/4-inch top flanges. (S) = Surface perforations.

FIGURE 4—DONN DXLT AND DXLF ONE-HOUR FIRE-RATED SYSTEMS



For SI: 1 inch = 25.4 mm, 1 pcf = 16.02 kg/m³, 1 psi = 6.89 kPa, 1 pound/yard² = 0.54 kg/m², 1 inch² = 645.16 mm², 1 foot² = 0.0929 m².

1. **Beam**—W8 × 24, minimum size.
2. **Normal-weight Concrete**—Carbonate or siliceous aggregate, 152 pcf ± 3 pcf unit weight, 4,500-psi compressive strength.
3. **Welded Wire Fabric**—6 by 6 inches, 10/10 SWG.
4. **Metal Lath**—³/₈-inch rib, 3.4-pound-per-square-yard expanded steel. Tied to each joist at every other rib and midway between joints at side lap with 18 SWG galvanized steel wire.
5. **Steel Joists**—Type 10J2 minimum size, spaced 24 inches on center, welded to end supports.
6. **Bridging**—¹/₂-inch-diameter steel bars welded to top and bottom chords of each joist.
7. **Hanger Wire**—No. 12 SWG galvanized steel wire tied to lower chord of joists or cold-rolled channels tied face to face with No. 18 SWG galvanized wire. Hanger wires spaced a maximum of 48 inches on center along main runners and located at ends of main runners at walls and at corners and midspan along 4-foot sides of light fixtures.
8. **Cold-rolled Channels**—No. 16 MSG cold-rolled steel, 1¹/₂ inches deep.
9. **Air-Duct**—No. 20 MSG galvanized steel. Total area of duct openings not to exceed 57 square inches per 100 square feet of ceiling area. Area of individual duct openings not to exceed 113 square inches. Maximum dimension of opening is 12 inches. Duct supported by cold-rolled channels, spaced approximately 24 inches on center.
10. **Damper**—No. 16 MSG galvanized steel, 16 by 16 inches, protected on both surfaces with ¹/₁₆-inch-thick ceramic fiber paper and held open with alisted fusible link. Damper to overlap duct outlet a minimum of 1 inch.
11. **Fixtures, Recessed Light**—Listed fluorescent-lamp type, steel housing, 2-by-4-foot size. Fixtures spaced so their area does not exceed 24 square feet per 100 square feet of ceiling area. Fixtures and ballasts must be considered for these ambient temperature conditions before installation.
12. **Fixture Protection**—Wallboard, gypsum—¹/₂- and ⁵/₈-inch-thick gypsum wallboard (SHEETROCK FIRECODE Type “C” as manufactured by United States Gypsum Company), cut into pieces to form a four-sided enclosure, trapezoidal in cross section, approximately ¹/₂ inch longer and wider than the fixture, with sufficient depth to provide at least ¹/₂ inch clearance between the fixture and the enclosure.
13. **Steel Framing Members**—Type DGL or DGLW—main runner tees, 12 feet long, spaced 4 feet on center. Main runner ends interlocked by an integral splice end detail. Type DGLW or DGCL cross channels, measuring 4 feet long, installed perpendicular to the main runners, spaced 24 inches on center. Additional channels placed 8 inches from light fixtures and from butted end joints. Channels clipped into main runner slots and secured to wall angle using ¹/₂-inch-long self-drilling and self-tapping screws having a thread diameter of 0.138 inch and a ⁵/₁₆-inch head diameter. The Type DGL cross tees, used to support the 4-foot sides of light fixtures, are 4 feet long and installed perpendicular to the main runners.
14. **Gypsum Wallboard**—¹/₂- and ⁵/₈-inch-thick gypsum wallboard (SHEETROCK FIRECODE Type “C” as manufactured by United States Gypsum Company), 4 feet wide, installed with the long dimension perpendicular to cross channels, with side joints centered along main runners. Wallboard fastened to cross channels using 1-inch-long wallboard screws located ¹/₂ inch from end joints and ¹/₄ inches from each side joint, and spaced 12 inches on center along the end joints and in the field.
15. **Metal Trim Molding**—No. 22 MSG molding measuring ⁵/₈ inch wide, with ⁹/₁₆- and ¹/₈-inch-long legs placed on wallboard edges around light fixtures and secured to the cross tees and main runners using 1-inch-long wallboard screws. Spacing of screws approximately 8 inches on center along the 4-foot side and 10 inches on center along the 2-foot side of light fixtures.
16. **Screw, Wallboard**—Type S-12, 1 inch long, self drilling and self tapping, 0.163-inch thread diameter, ⁵/₁₆-inch head diameter.
17. **Finishing System**—Paper tape embedded in compound over joints and covered with additional compound. Exposed screw heads covered with compound. Edges of compound feathered out.
18. **Wall Angle**—(Not shown)—No. 26 MSG angle with ¹/₈-inch legs, nailed to the walls supporting the cross channels.

FIGURE 5—FIRE-RESISTIVE FLOOR-CEILING ASSEMBLY UTILIZING THE USG DONN DRYWALL SUSPENSION SYSTEM

ICC-ES Evaluation Report

ESR-1222 Supplement

Issued December 1, 2011

This report is subject to renewal in two years.

www.icc-es.org | (800) 423-6587 | (562) 699-0543

A Subsidiary of the International Code Council®

DIVISION: 09 00 00—FINISHES

Section: 09 22 26—Suspension Systems

Section: 09 53 00—Acoustical Ceiling Suspension Assemblies

REPORT HOLDER:

USG INTERIORS, LLC
550 WEST ADAMS STREET
CHICAGO, ILLINOIS 60661
(800) 874-4968www.usg.com
usg4you@usg.com

EVALUATION SUBJECT:

USG DONN®, SIMPLICITEE®, DONN FINELINE®, DONN CENTRICITEE™ AND DONN MERIDIAN® ACOUSTICAL TILE SUSPENDED CEILING FRAMING SYSTEMS; USG DONN PARALINE® SUSPENDED CEILING SYSTEM; DONN DRYWALL SUSPENDED CEILING SYSTEM; DONN SEISMIC COMPRESSION POST; AND ACM7 CEILING ATTACHMENT CLIP

1.0 EVALUATION SCOPE

Compliance with the following code:

2010 California Building Code (CBC)

Properties evaluated:

- Interior finish
- Fire resistance
- Structural

2.0 PURPOSE OF THIS SUPPLEMENT

This supplement is issued to indicate that the USG Donn®, Smplicitée®, Donn Fineline®, Donn Centricitee™ and Donn Meridian® Acoustical Tile Suspended Ceiling Framing Systems; USG Donn Paralinee® Suspended Ceiling System; Donn Drywall Suspended Ceiling System; Donn Seismic Compression Post; and ACM7 Ceiling Attachment Clip, described in master report ESR-1222, comply with the CBC, when design and installation are in accordance with the master evaluation report with the following modifications:

Modify Section 3.5.2 (Hanger Wire) as follows: Hanger wire for suspended ceiling framing members, and fixtures, must comply with ASTM C 636 as referenced in CBC Sections 808, 1615.10.13 and 1615A.1.16, and Section 13.5.6 of ASCE 7 as referenced in CBC Sections 1613, 1615.10.13, 1615A.1.16 and 2506.2.1, and with ASTM E 580 as referenced in CBC Sections 1615.10.13 and 1615A.1.16, as applicable.

Modify Section 4.1.1 (General) as follows: The suspended ceiling framing system installed with acoustical tiles or Paralinee pans must be designed and installed in accordance with Section 13.5.6 of ASCE 7 as referenced by CBC Sections 1613 and 1613A, and CBC Section 808.1, and modified by CBC Sections 1615.10.13 and 1615A.1.16, as applicable. The minimum tension and compression capacity of the ceiling framing member connections is 180 pounds (800 N).

Modify Section 4.1.4.1 (Seismic Design: General) as follows: Seismic design and installation details of the ceiling system, including lighting fixtures and mechanical services, must be in accordance with Section 13.5.6 of ASCE 7 as referenced in CBC Sections 1613 and 1613A, and modified by CBC Sections 1615.10.13 and 1615A.1.16, as applicable, except as noted in Section 4.3 of this report. Systems with main runners described in the master report Table 1, classified as intermediate-duty, are limited to use in Seismic Design Categories A, B and C. Lighting fixtures may also be attached to the

grid with clips complying with the ICC-ES Acceptance Criteria for Attachment Devices for Recessed Lighting Fixtures (Luminaires) in Suspended Ceiling Systems (AC184).

Modify Section 4.1.4.2 (Seismic Design: Partitions) as follows: Partitions must be laterally supported as required by Section 13.5.8 of ASCE 7 as referenced by CBC Sections 1613 and 1613A, and CBC Sections 1615.10.13 and 1615A.1.16, as applicable.

Modify Section 4.2 (Suspended Ceiling Systems for Gypsum Wallboard) as follows: The installation must be in accordance with Section 4.1, except the ceilings must be designed for seismic loads required under Chapter 13 of ASCE 7 as referenced by CBC Sections 1613 and 1613A, and modified by CBC Sections 1615.10.13 and 1615A.1.16, as applicable. The ceiling weight must not exceed 4 psf (19.5 kg/m²).

Modify Section 4.3.1 (Alternate Installation for Seismic Design Categories D, E and F) as follows: With this installation, the DX main and cross runners must be main and cross runners as described in Section 3.5.1 of the master report. Maximum total ceiling weight permitted is 2.5 lb/ft² (12.19 kg/m²). The ACM7 clips are used to secure the main runners and cross runners to the perimeter members (wall closures or wall moldings) on two adjacent walls and to allow free movement of the runners on the two opposing walls. See Figures 1 and 2 of the master report. A nominally 7/8-inch-wide (22 mm) wall closure angle (molding) is used in lieu of the 2-inch-wide (50.8 mm) perimeter wall molding required by Section 13.5.6.2.2 of ASCE 7 and Section 5.2.2 of ASTM E 580 for Seismic Design Categories D, E and F. Except for the use of the ACM7 clips and the nominal 7/8-inch-wide (22 mm) wall molding and the elimination of spacer bars, installation of the ceiling system must be as prescribed by the applicable code.

The ACM7 clip is attached to the wall molding by sliding the locking lances over the hem of the vertical leg of the wall molding. On the two adjacent walls where the runners are fixed, the clips are attached to the runner by a sheet metal screw through the clip into the bulb of the tee. On the walls where the runners are not fixed, the clips allow the terminal runner end to move 3/4 inch (19.1 mm) towards and away from the wall. The ACM7 clips installed in this manner are used in lieu of the spacer bars (stabilizer bars) required in CISCAs 3-4 and ASTM E 580. CISCAs 3-4 is referenced in ASCE-7, Section 13.5.6.2.2, which is referenced in CBC Sections 1613 and 1613A. ASTM E 580 is referenced in CBC Sections 1615.10.13 and 1615A.1.16.

Modify Section 4.3.2 (Alternate Installation for Seismic Design Categories A, B and C) as follows: The ACM7 clip may be used in lieu of spacer bars (stabilizer bars) in suspended ceiling installations regulated by CISCAs 0-2 and Section 4.2.5 of ASTM E 580. The ACM7 clip is attached to the wall molding by sliding the locking lances over the hem of the vertical leg of the wall molding and using one fastener through the wall molding. The clips are placed at the intersections of all runners and the wall angle (molding). The clips must be positioned to allow a minimum 3/8-inch (9.5 mm) movement in both directions (towards and away from the wall). The maximum ceiling weight permitted is 2.27 lb/ft² (11.06 kg/m²). See Figure 2 of the master report. Except for the use of the ACM7 clip and the elimination of spacer bars (stabilizer bars), installation of the ceiling system must be as prescribed by the applicable code. This construction is equivalent to that required by CISCAs 0-2 and Section 4 of ASTM E 580. CISCAs 0-2 is referenced in ASCE-7, Section 13.5.6.2.1, which is referenced in CBC Sections 1613 and 1613A. ASTM E 580 is referenced in CBC Sections 1615.10.13 and 1615A.1.16.

Modify Section 4.4.5 (Donn Drywall Suspended Fire-resistance-rated Ceiling Systems), second paragraph, as follows: The ratings apply to restrained and unrestrained assemblies as described in ASTM E 119, which is referenced in CBC Section 703. General requirements of CBC Section 712.1 must be observed.

Modify Section 4.5 (Special Inspection) as follows: Suspended ceilings that are part of building structures assigned to Seismic Design Categories D, E and F must be subject to periodic special inspections during the installation of the suspended ceiling systems and their anchorage, in accordance with the requirements of CBC Section 2506.2.1, Section 13.5.6.2.2 (h) of ASCE 7, and CBC Sections 1705.3.4 and 1705A.3.4, Item 3. The special inspector must verify that the ceiling system is as described in this report, and complies with the installation instructions in this report, and with the approved construction documents.

Modify Section 5.3 as follows: Suspended ceiling systems must be designed in accordance with Section 13.5.6 of ASCE 7 as referenced by CBC Sections 1613 and 1613A, and modified by CBC Sections 1615.10.13 and 1615A.1.16, as applicable. The documents must be prepared by a registered design professional where required by the statutes of the jurisdiction in which the project is to be constructed.

Modify Section 5.4 as follows: For Seismic Design Category C, D, E or F, a quality assurance plan complying with CBC Chapters 17 and 17A, as applicable, must be submitted to the code official for approval.

Modify Section 5.5 as follows: Periodic special inspections must be provided in accordance with Section 4.5 of this report. A statement of special inspection must be provided as required in CBC Sections 1705.3.4 and 1705A.3.4, Item 3.

Modify Section 5.6 as follows: The ceiling framing systems must not be used to provide lateral support for walls or partitions, except as provided for in ASCE 7, Section 13.5.8.1, as referenced in CBC Sections 1613 and 1613A, and must comply with applicable code provisions referenced in Section 4.1.4 of this report.

Modify Section 5.7 as follows: The ceiling framing systems must be braced to resist seismic forces as determined from Sections 1613 and 1613A of the CBC, and modified by CBC Sections 1615.10.13 and 1615A.1.16, as applicable.

Modify Section 5.9 as follows: The ceiling framing systems are limited to ceilings not considered accessible in accordance with Item 31 of CBC Tables 1607.1 and 1607A.1.

Modify Section 5.11 as follows: Lay-in ceiling panels must be justified to the satisfaction of the code official as complying with the interior finish requirements of Chapter 8 of the CBC.