

SA932 09305

DUROCK[®]



cement board systems



USG DUROCK[®]
Cement Board NEXT GEN
LIGHTER. EASIER. FASTER.

**DUROCK® Brand
Cement Board Systems**

<p>DUROCK® Cement Board</p>	<p>DUROCK cement board offers architects, builders and tile contractors a strong, water-durable tile base for tub and shower areas. Also an ideal underlayment for tile on floors and countertops in new construction and remodeling. Board is readily applied over wood or steel framing spaced 16" o.c. with corrosion-resistant wood or steel screws or hot-dipped galvanized roofing nails. After joints are treated, ceramic wall or floor tile is applied using latex-fortified mortar or Type I organic adhesive.</p> <p>DUROCK cement board is preferred by many applicators as a base for directly applied finishes, tile, stone and thin-brick used in building exteriors.</p>
<p>DUROCK™ Tile Backer Screws</p>	<p>Corrosion-resistant; 8-gauge; wafer heads with countersinking ribs to prevent strip-out; self-drilling points. DUROCK tile backer screws for wood framing come in three lengths: 1-1/4", 1-5/8" and 2-1/4". DUROCK tile backer screws for steel framing can be used with steel framing where steel thickness is from 14 to 20-gauge; they come in two lengths: 1-1/4" and 1-5/8". Both wood and steel screws have heads a minimum of 0.40" in diameter; their driving recess is a No. 2 "Phillips" design.</p>
<p>DUROCK™ Tile Backer Tape</p>	<p>Alkali-resistant glass-fiber tape reinforces joints to provide a strong, continuous surface. Each roll 2" x 50', 2" x 150', 2" x 250' or 4" x 150'.</p>
<p>Features and Benefits of DUROCK Cement Board</p>	<p>Dual Surface Although both sides of DUROCK cement board are suitable for either mastic or thin-set mortar applications, the following is offered as a guide:</p> <ul style="list-style-type: none"> – Smooth side for mastic applications; increases adhesive coverage – Textured surface enhances bonding, reduces tile slip with mortar applications <hr/> <p>Dimensional Stability</p> <ul style="list-style-type: none"> – Low thermal and hygrometric expansion helps prevent cracking – Will not swell, soften, decay, delaminate or disintegrate in water <hr/> <p>Fire-Resistance</p> <ul style="list-style-type: none"> – Noncombustible panel – Assemblies with 1/2" DUROCK cement board have achieved 1- and 2-hour fire-resistance ratings <hr/> <p>Light Weight</p> <ul style="list-style-type: none"> – At approximately 2.4 psf, the 1/2" thick board is approximately 25% lighter than other cement boards <hr/> <p>Easy Installation</p> <ul style="list-style-type: none"> – Easy to cut and fasten – Installs up to 20% faster than other cement boards <hr/> <p>Convenient Sizes</p> <ul style="list-style-type: none"> – May be ordered in sizes to meet job requirements (see table of sizes and packaging) <hr/> <p>Versatility</p> <ul style="list-style-type: none"> – Provides a smooth, sound base for glass and ceramic mosaics; ceramic and quarry tile; lugged tile; thin stone tile; and thin brick – Adaptable for fences, fireplace fronts, mobile home skirting, agricultural buildings, garage wainscoting and various exterior synthetic stucco systems.
<p>Limitations</p>	<ol style="list-style-type: none"> 1. Designed for positive or negative uniform loads up to 60 psf. For complete information on the use of DUROCK panels in exterior systems, consult uniform load table on page 3 for applicable positive or negative uniform loads on wall systems. 2. Wall applications: Maximum stud spacing: 16" o.c. (24" o.c. for cavity shaft wall assembly). Framing shall be designed (based on stud properties alone) not to exceed L/360 deflection for tile and thin brick, L/240 for direct-applied exterior finish systems. Maximum fastener spacing: 8" o.c. for wood and steel framing; 6" o.c. for ceiling applications. 3. Floor applications: Maximum joist spacing 24" o.c. The subfloor system should be designed with a minimum deflection limit of L/360 for the span. Some finish materials may require a more rigid sub-assembly (such as large format tile and natural stone products). In these cases, follow the manufacturer's minimum requirements. The subfloor should be APA Span-Rated Plywood or OSB with an Exposure 1 classification or better with tongue and groove or back blocked at the unsupported edges. 4. Maximum dead load for ceiling system is 7.5 psf. 5. Steel framing must be 20-gauge equivalent or heavier. 6. Do not use drywall screws or drywall nails. Do not use drywall joint tape. 7. Do not use 1/4" DUROCK cement board for wall or ceiling applications. 8. Do not use DUROCK cement board with vinyl flooring. 9. DUROCK cement board is not designed for use as a structural panel.

Product Data

Material – Formed in a continuous process of aggregated portland cement slurry with polymer-coated, glass-fiber mesh completely encompassing edges and back and front surfaces.

Edges – Formed smooth.

Ends – Square cut.

Sizes and Packaging

Type	Size (thickness x width x length) ¹	Units (pcs) ²
Cement Board	1/2" x 32" x 5'	50
	1/2" x 36" x 5'	50
	1/2" x 32" x 8'	30
	1/2" x 48" x 8'	30
	5/8" x 36" x 5'	30
	5/8" x 48" x 8'	24
	1/4" x 36" x 5'	60

1. Other lengths available. Contact your USG Representative. 2. Shipped in packaging units as shown.

Technical Data

Property	Unit of Measure	ASTM Test Method	5/8" DUROCK Cement Board	1/2" Cement Board	1/4" Underlayment
Flexural strength	psi	C947	> 480	> 750	> 1000
Indentation strength	psi	D2394	> 1250	> 1250	> 1250
Shear bond strength	psi	ANSI A118.4	> 50	> 50	> 50
Water absorption	% by wt. 24 hrs.	C473	15	15	15
Nail-pull resistance	lb. (0.4" head diameter, wet or dry)	C473	> 90	> 90	—
Weight	psf	C473	3	2.4	< 1.9
Freeze/thaw resistance	procedure B, number of cycles with no deterioration	C666	100	100	100
Mold resistance	—	G21	No growth	No growth	No growth
Noncombustibility	Pass/Fail	E136	Pass	Pass	Pass
Surface burning characteristics	flame/smoke	E84	0/0	0/0	0/0
Thermal	"R"/k value	C518	.49/1.27	0.39/1.27	—
Standard method for evaluating ceramic floor tile installation systems	Passes cycles 1-6	C627	Light commercial	Light commercial	Light commercial
Minimum bending radius	ft. (requires special framing details available upon request)	—	6	6	—

**Uniform Load —
1/2" DUROCK
Cement Board**

Stud Spacing	Fastener Spacing	Design Wind Load (I/240)	Design Wind Load (I/360)
12" o.c.	8" o.c.	45 psf	45 psf
	6" o.c.	60 psf	60 psf
16" o.c.	8" o.c.	33 psf	30 psf
	6" o.c.	45 psf	30 psf
24" o.c. (for shaft wall assemblies only)	8" o.c.	13 psf	9 psf
	6" o.c.	13 psf	9 psf

Standards

DUROCK cement board exceeds the ANSI Standards for cementitious backer units (CBU). See ANSI A1 18.9 for Test Methods and Specifications for CBU and ANSI A108.11 for Interior Installation of CBU. All DUROCK cement board products meet ASTM Standard E136 for noncombustibility. Exceeds ASTM C1325 standards for non-asbestos fiber-mat reinforced cementitious backer units.



DUROCK
Cement Board Systems

Partitions

1-Hour Fire-Rated Construction		Non-Loadbearing, Steel Framed	Acoustical Performance		
Construction Detail	Description	Test Number	STC	Test Number	
	<ul style="list-style-type: none"> • 1/2" DUROCK cement board – 3-1/2" 20 gauge steel studs 16" o.c. – 3" ROXUL mineral wool AFB • 5/8" SHEETROCK® brand FIRECODE® Core gypsum panels, one side 	U433			
2-Hour Fire-Rated Construction		Non-Loadbearing, Steel Framed	Acoustical Performance		
Construction Detail	Description	Test Number	STC	Test Number	
	<ul style="list-style-type: none"> • 1/2" DUROCK cement board and 1/4" ceramic tile • base layer 1/2" SHEETROCK® brand FIRECODE® C Core gypsum panels – 3-5/8" 20-gauge steel studs 16" o.c. – 3" THERMAFIBER SAFB – face layer joints taped • alternate design 2 layers 1/2" SHEETROCK FIRECODE C Core gypsum panels, one side 	U443	56	SA-851016 Based on alternate Design	
			58	SA-851028	
1-Hour Fire-Rated Construction		Chase Walls, Steel Framed	Acoustical Performance		
Construction Detail	Description	Test Number	STC	Test Number	
	<ul style="list-style-type: none"> • face layer 1/2" DUROCK cement board • base layer 5/8" SHEETROCK FIRECODE Core gypsum panels or sheathing, or FIBEROCK® brand panels – 3-1/2" 20-gauge steel studs 16" o.c. – 3" mineral wool batt • 5/8" SHEETROCK FIRECODE Core opposite side 	UL Des U473			
1-Hour Fire-Rated Construction		Loadbearing, Wood Framed	Acoustical Performance		
Construction Detail	Description	Test Number	STC	Test Number	
	<ul style="list-style-type: none"> • 1/2" DUROCK cement board and 1/4" ceramic tile – 2 x 4 wood studs 16" o.c. – 3-1/2" THERMAFIBER SAFB – joints taped • alternate design 5/8" SHEETROCK FIRECODE Core gypsum panels, one side 	UL Des U329	37	USG-840404	
			40	USG-830314	
	<ul style="list-style-type: none"> • 1/2" DUROCK cement board – base layer 15/32" plywood – 2 x 4 wood studs 16" o.c. – 3" THERMAFIBER SAFB – joints taped and treated • 5/8" SHEETROCK FIRECODE Core gypsum panels, other side 	U303			
2-Hour Fire-Rated Construction		Chase Walls, Steel Framed	Acoustical Performance		
Construction Detail	Description	Test Number	STC	Test Number	
	<ul style="list-style-type: none"> • 1/2" DUROCK cement board and 1/4" ceramic tile – Two rows 2 x 4 16" o.c. on 2 x 8 common plate – 3-1/2" THERMAFIBER SAFB both cavities – joints taped – load-bearing up to 50% allowable design load 	WHI-495-0505 and 0508	50	SA-840523	

Roof / Ceilings

1-Hour Fire-Rated Construction		Steel Truss	Acoustical Performance		
Construction Detail	Description	Test Number	STC	ITC	Test Number
	<ul style="list-style-type: none"> • 5/8" SHEETROCK FIRECODE C Core gypsum panels – RC-1 channels or equivalent – joints finished – steel roof deck – steel truss 48" o.c. • roof covering and roof insulation over 1/2" DUROCK cement board or 1/2" SHEETROCK® gypsum panels 	UL Des P521, P525, 527, 529			

DUROCK
Cement Board Systems

Floor / Ceilings

2-Hour Fire-Rated Construction		Dimensional Lumber, Wood Framed	Acoustical Performance			
Construction Detail	Description	Test Number	STC	ITC	Test Number	
	<ul style="list-style-type: none"> • Two layers 5/8" SHEETROCK FIRECODE C Core gypsum panels – 8" x 8" ceramic tile • 1/2" DUROCK cement board • 1" SHEETROCK® gypsum liner panels – 1/2" plywood – 2 x 10 wood joist 16" o.c. – 3" mineral wool batt – RC-1 channel or equivalent 	UL Des L541		52	RAL-IN-89-5	
			58		RAL-TL-89-145	
				51		RAL-IN-89-7
			59		RAL-TL-89-146 Based on carpet/pad over oriented strand board in place of ceramic tile and cement board	
			60		RAL-TL-89-141	
		62		RAL-IN-89-8		

Exterior Walls

2-Hour Fire-Rated Construction		Steel Framed, Non-Loadbearing	Acoustical Performance		
Construction Detail	Description	Test Number	STC	ITC	Test Number
	<ul style="list-style-type: none"> • 1/2" DUROCK cement board • base layer 1/2" SHEETROCK® MOLD TOUGH® FIRECODE® C Core gypsum panels, both sides – 3-5/8" 20-gauge minimum steel studs 16" o.c. – 3" THERMAFIBER SAFB • alternate design, double-layer 1/2" SHEETROCK FIRECODE C Core gypsum panels, interior 	UL Des U474			
1-Hour Fire-Rated Construction		Steel Framed, Non-Loadbearing	Acoustical Performance		
Construction Detail	Description	Test Number	STC	ITC	Test Number
	<ul style="list-style-type: none"> • 1/2" DUROCK cement board • base layer 5/8" SHEETROCK MOLD TOUGH FIRECODE Core gypsum panels – 3-1/2" 20 gauge steel load-bearing studs 16" o.c. – 3" THERMAFIBER SAFB • 5/8" SHEETROCK FIRECODE Core gypsum panels, interior side 	UL Des U473			
1-Hour Fire-Rated Construction		Wood Framed, Loadbearing	Acoustical Performance		
Construction Detail	Description	Test Number	STC	ITC	Test Number
	<ul style="list-style-type: none"> • 1/2" DUROCK cement board, interior side – 15/32" plywood – 2 x 4 wood studs 16" o.c. – 3" THERMAFIBER SAFB – joints finished • 5/8" SHEETROCK FIRECODE Core gypsum panels or SECUROCK® glass-mat sheathing panels, other side 	UL Des U303			
1-Hour Fire-Rated Construction		Wood Framed, Loadbearing	Acoustical Performance		
Construction Detail	Description	Test Number	STC	ITC	Test Number
	<ul style="list-style-type: none"> • 1/2" DUROCK cement board and 1/4" ceramic tile exterior – 2 x 4 wood studs 16" o.c. – 3-1/2" THERMAFIBER SAFB • 5/8" SHEETROCK FIRECODE Core gypsum panels – optional veneer plaster 	UL Des U329			

Notes: DUROCK cement board, 5/8" thick, may be substituted for 1/2" cement board panels in all assemblies listed above. FIBEROCK® abuse-resistant gypsum fiber panels, 5/8" thick, may be substituted for 1/2" SHEETROCK FIRECODE C Core gypsum panels, or 5/8" SHEETROCK FIRECODE Core gypsum panels, in all assemblies listed above. Where thermal insulation is shown in assembly drawing, the specific product is required in the assembly to achieve the stated fire rating. Fiberglass insulation cannot be substituted for THERMAFIBER insulation. Where the wall is exposed to moisture, use a moisture-resistant barrier behind the cement board.

1. Steel framing must be 20 gauge or heavier.
2. Estimate based on 25-gauge steel studs.

DUROCK Cement Board Systems

Countertops

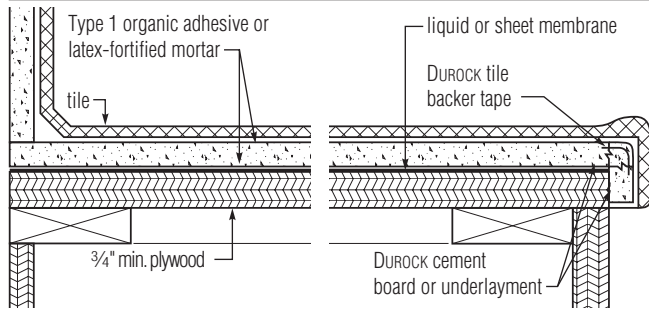

Floors, interior—wood or steel joists

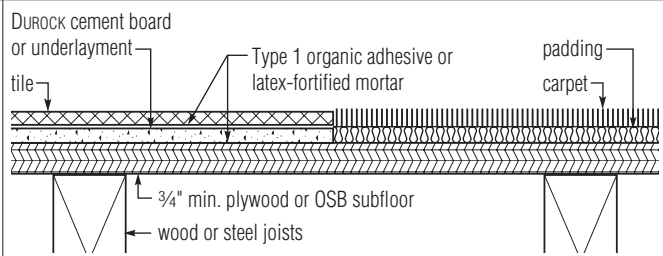

Note: For bonding cement backerboard to plywood subfloor, use Type 1 organic adhesive or latex-fortified mortar that is suitable for this kind of application. For application of various types of tiles to cement backerboard on floors or countertops, contact the tile manufacturer for the appropriate type of tile-setting mortar.

Suspended ceiling detail

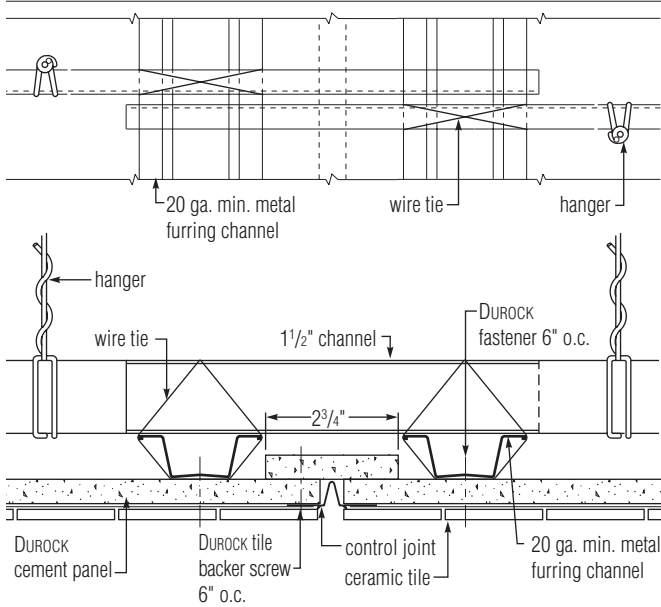

Wood soffit framing

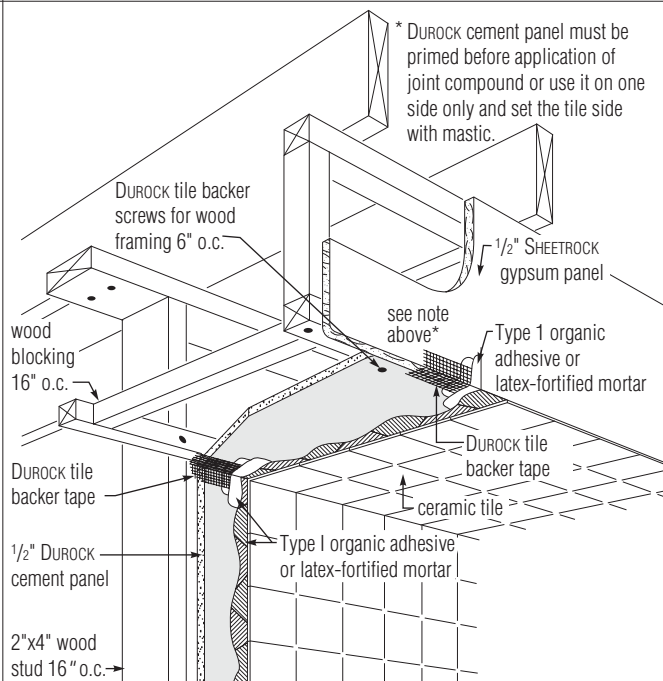

Tub and shower—single layer board

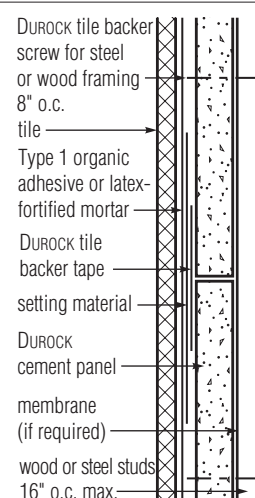
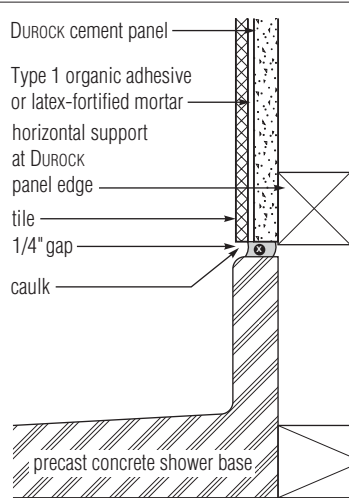
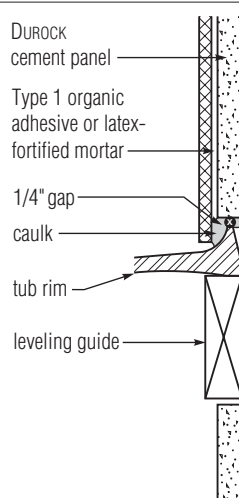
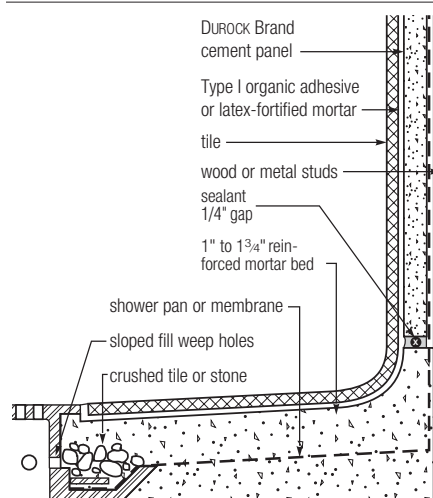

Walls, interior and exterior—wood or steel studs

DUROCK Cement Board Systems

Typical bathtub installation

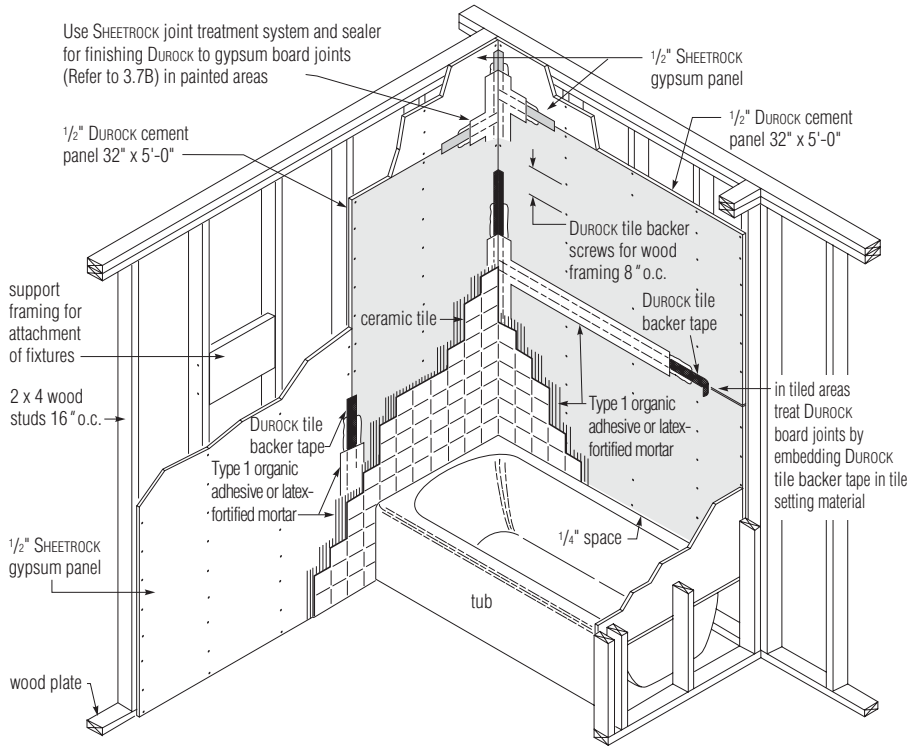

Fixture attachment — steel framing

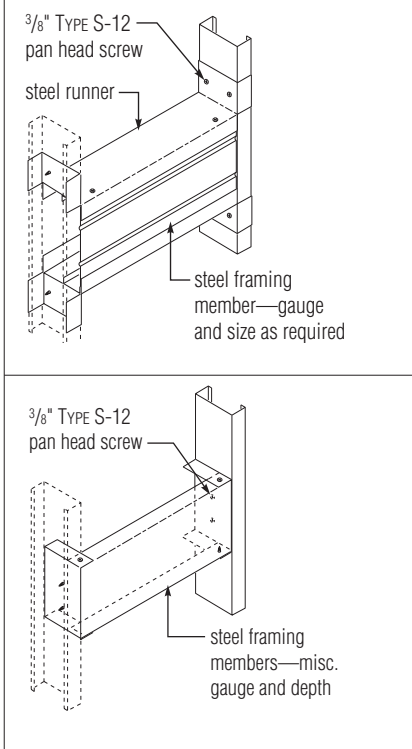

Typical swimming pool installation (tile or exterior finish)

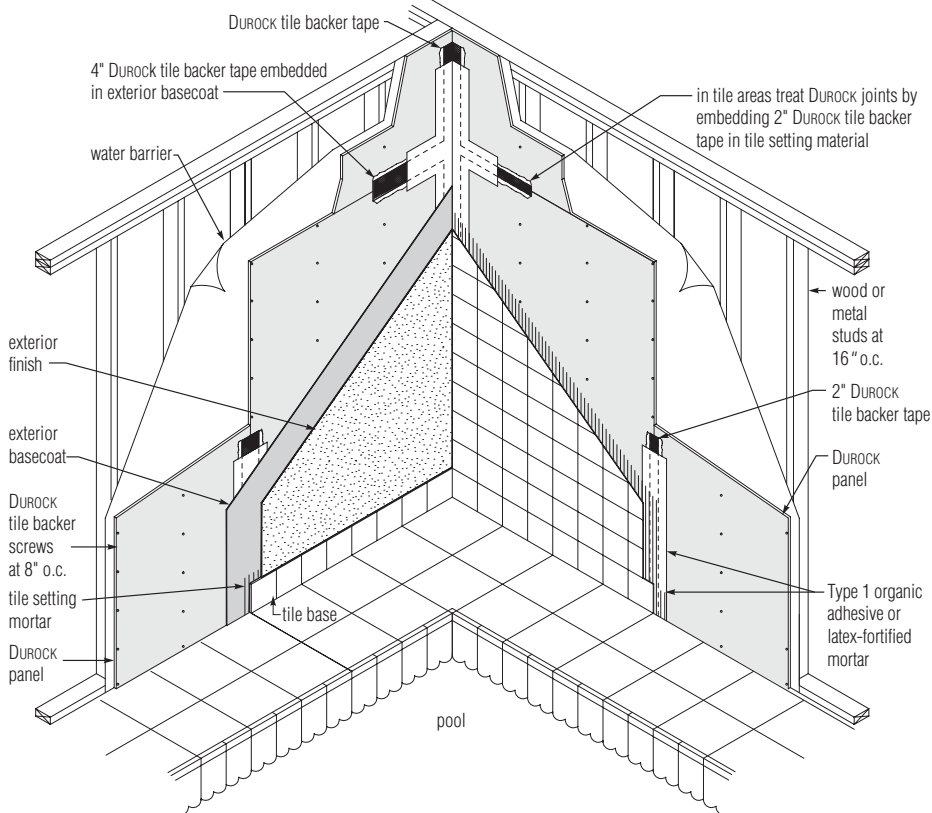

Durock alkali-resistant tape

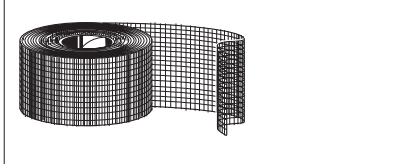

Durock tile backer screws for wood framing

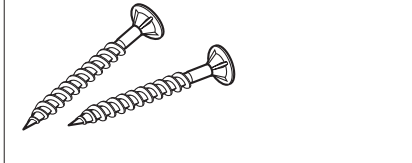

Durock tile backer screws for steel framing

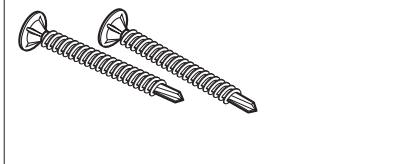

Hot-dipped galvanized roofing nails

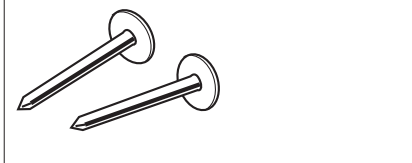

DUROCK
Cement Board Systems

Good Design Practices

<p>1. System Performance</p>	<p>Systems covered herein have been tested and evaluated for use as described. For other system applications, consult your local representative.</p> <p>All details, specifications and data contained in this literature are intended as a general guide for using DUROCK cement board systems. These products must not be used in a design or construction of any given structure without complete and detailed evaluation by a qualified structural engineer or architect to verify suitability of a particular product for use in the structure.</p> <p>Information in this publication should be used only for DUROCK cement board systems, as physical properties of competitive products may vary. United States Gypsum Company assumes no liability for failure resulting from the use of alternative materials or improper application or installation of DUROCK cement board systems as specified herein.</p> <p>United States Gypsum Company will provide building officials and design professionals upon written request with test certification for published fire, sound and structural data covering systems constructed with Company products and assembled to meet performance requirements of established test procedures specified by various agencies.</p>
<p>2. Expansion and Contraction</p>	<p>Wall surfaces should be isolated with surface control joints (sometimes referred to by the industry as expansion joints) or other means where: (a) a wall abuts a structural element or dissimilar wall or ceiling; (b) construction changes within the plane of the wall; (c) tile and thin brick surfaces exceed 16'. Surface control joint width should comply with architectural practices.</p> <p>Location of building control joints is the responsibility of the design professional/architect. Steel framing at building control joints that extend through the wall (with top and bottom runner tracks broken) should have 1-1/2" cold-rolled channel alignment stabilizers spaced a maximum of 5' o.c. vertically. Channels should be placed through holes in the stud web of the first two adjacent studs on both sides of the joint and securely attached to the first adjacent stud on either side of the joint.</p> <p>Cement board should be separated at all surface and building control joints. Where vertical and horizontal joints intersect, the vertical joint should be continuous and the horizontal joint should abut it. Splices, terminals and intersections should be caulked with a sealant complying with architectural practices and sealant manufacturer recommendations. Do not apply tile or finishes over caulked sealed expansion joints.</p>
<p>3. Water Management</p>	<p>DUROCK cement board is vapor permeable and does not deteriorate in the presence of water. For interior applications, if a vapor retarder or waterproof construction is specified, a separate barrier must be applied over or behind the DUROCK cement board. If waterproofing is desired, use DUROCK tile membrane. See USG literature piece CB492 for DUROCK tile membrane product information.</p>
<p>4. Swimming Pool Enclosures</p>	<p>DUROCK cement board systems may be used for the walls and ceilings around indoor swimming pools. Consideration shall be given to adequate ventilation in plenums and corrosion protection of metal hangers and framing members.</p>
<p>5. Soffits and Ceilings</p>	<p>DUROCK cement board systems finished with ceramic tile, thin brick and textured finish may be used on properly vented soffits and ceilings with DUROCK tile backer screws spaced 6" o.c. max. A qualified structural engineer should evaluate design including uplift bracing.</p>
<p>6. Steam Rooms and Saunas</p>	<p>For steam rooms and saunas where temperatures exceed 120 °F for extended periods, use latex-fortified portland cement mortar; do not use organic adhesive.</p>
<p>7. Abuse Resistant Partitions</p>	<p>IMPERIAL® brand finish plaster and DIAMOND® interior finish plaster can be applied over DUROCK cement board to provide a high-impact resistant wall. See United States Gypsum Company publication SA920 for specifications.</p>
<p>8. Window and Door Openings</p>	<p>All windows, door openings and termination points must be properly flashed and caulked.</p>
<p>9. Smooth Side/Rough Side</p>	<p>DUROCK cement board has a smooth side and a rough side. Although both sides of DUROCK cement board are suitable for either mastic or thin-set mortar applications, as a general guide, use the smooth side for mastic applications and the rough side for mortar applications.</p>
<p>10. Shadowing and Spotting</p>	<p>When the outside temperature differs considerably from the building's interior temperature, airborne dirt can accumulate on the colder regions of walls, causing "shadowing" or "spotting," particularly over fasteners and framing. This is a natural phenomenon that occurs through no fault in the products.</p> <p>Where temperature, humidity and soiling conditions are expected to cause objectionable blemishes, provide a thermal separation between the interior and exterior faces.</p>

DUROCK
Cement Board Systems

	11. Leaching and Efflorescence	Latex leaching and efflorescence are natural phenomena that occur with the use of latex modified mortars and grouts through no fault in the products. To help protect against their occurrence, follow current industry guidelines and recommendations. If efflorescence is present, use a stiff nylon brush to remove any loose material.
	12. Panel Micro-Cracking	DUROCK cement board is formulated to develop fine micro-cracking (also called multiple-cracking) in the panel. The micro-cracking process helps to evenly relieve the stored strain energy in the product due to handling and installation, external loads, and/or panel restrained movement. The presence of micro-cracks in the panel should not be considered a product defect.
	13. Vapor Retarders	Humidity and temperature conditions may require a vapor retarder. Its location should be determined by a qualified mechanical engineer or architect to prevent moisture condensation within the wall.
	14. Corrosion Protection	All architectural components, such as anodized-aluminum window frames, trims, flashings and casings, shall be protected from alkaline building materials such as cement board, portland cement basecoats, mortars and grouts.
Specifications Part 1: General	1.1 Scope	Specify to meet project requirements.
	1.2 Qualifications	All materials, unless otherwise indicated, shall be manufactured by United States Gypsum Company and shall be installed in accordance with its current printed directions.
	1.3 Delivery and Storage of Materials	All materials should be delivered and stored in their original unopened package and stored in an enclosed shelter providing protection from damage and exposure to the elements. Even though the stability and durability of DUROCK cement board is unaffected by the elements, moisture and temperature variations may have an effect on the bonding effectiveness of basecoats and adhesives. Store all DUROCK cement board panels flat.
	1.4 Environmental Conditions	<p>In cold weather and during DUROCK cement panel and tile installation, temperatures within the building shall be maintained within the range of 40 to 100 °F. Adequate ventilation shall be provided to carry off excess moisture.</p> <p>Interior Applications Wood framing shall approximate the moisture content it will reach in service by allowing the enclosed building to stand as long as possible prior to the application of the cement board. Do not install board when the board is wet.</p> <p>Exterior Applications Finishes, leveling/skim coats and basecoats shall not be applied to a DUROCK cement panel that is wet or frozen or that contains frost. After application, and for at least 24 hours, finishes, leveling/skim coats and basecoats shall be effectively protected from rain and excessive moisture.</p> <p>In cold weather and during finish applications, DUROCK cement panel, skim or basecoat, mortar, finish material and air temperature must be at least 40 °F, and must remain at this temperature or higher for at least 24 hours after application. Hot and dry weather may affect working time of leveling/skim or basecoat and finish materials. Under rapid drying conditions, dampening or light fogging of board, leveling/skim or basecoat surface may be required to improve workability.</p>
	1.5 Framing	Steel or wood wall framing to receive DUROCK cement panels shall be structurally sound, free from bow and in general compliance with local building code requirements. Damaged and excessively bowed studs shall be replaced before installation of DUROCK cement panels. Framing shall be designed (based on stud properties alone) not to exceed L/360 deflection for tile and thin brick, L/240 for Direct-Applied Exterior Finish Systems. Steel framing must be 20-gauge equivalent or heavier with corrosion-resistant metal coating equivalent to G60 hot-dipped galvanized. Exterior steel framing should be laterally braced.
	1.6 Installation Practices	<p>DUROCK cement panel should be cut to size with utility knife and straight edge. Power saw should be used only if equipped with a dust-collection device and a NIOSH/MSHA-approved respirator is worn.</p> <p>Contractors installing tile and tile-setting materials should always follow current ANSI specifications and TCNA guidelines.</p>

DUROCK
Cement Board Systems

Part 2: Products	2.1 Materials	<p>A Cement Board</p> <ul style="list-style-type: none"> – DUROCK cement board, 1/2" or 5/8" thickness, 32", 36", or 48" width x lengths of 4' to 10'; exceeds ANSI A118.9 for cementitious backer units. – DUROCK underlayment, 1/4" thickness, 3' width x 5' length, other sizes available. <p>B Joint Reinforcement—DUROCK tile backer tape (alkali-resistant), 2" x 50', 2" x 150', 2" x 250', or 4" x 150'.</p> <p>C Fasteners</p> <ul style="list-style-type: none"> – DUROCK tile backer screws for steel framing (No. 8), 1-1/4" and 1-5/8" for 14- to 20-gauge steel framing; DUROCK tile backer screws for wood framing (No. 8), 1-1/4", 1-5/8", and 2-1/4" for wood framing. – Nails (1-1/2" hot-dipped galvanized roofing nails). <p>D Subfloor—5/8" or 3/4" plywood or oriented strand board (OSB), 4' x 8' sheets, exterior grade or superior.</p> <p>E Adhesives/Mortars</p> <p>Products compatible with alkaline or portland cement-based DUROCK cement board include, but are not limited to the following:</p> <ul style="list-style-type: none"> – Meeting ANSI A136.1 Type 1. – Meeting ANSI A118.1: dry-set mortar mixed with acrylic latex additive. – Meeting ANSI A118.4: latex portland cement mortar. <p>F Grout</p> <p>Products compatible with high pH-based DUROCK cement board:</p> <ul style="list-style-type: none"> – Meeting ANSI A118.6 or ANSI A118.7 or ANSI A118.8. <p>G Tile—Tile shall meet ANSI A137.1.</p> <p>H Membrane—DUROCK tile membrane, 15-lb. felt or 4-mil polyethylene membrane, if required, in accordance with local building codes.</p>
Part 3: Installation	3.1 Floors	<p>A Panel Application—Laminate DUROCK cement board to subfloor using Type 1 organic adhesive, latex-fortified mortar or dry-set mortar mixed with acrylic latex additive that is suitable for bonding cement backer board to plywood subfloor, with 1/4" square-notched trowel for mortar, 5/32" V-notched trowel for adhesive. Place cement board with joints staggered from subfloor joints. Fit ends and edges closely but not forced together. Fasten to subfloor with 1-1/4" DUROCK tile backer screws for wood framing or 1-1/2" hot-dipped galvanized roofing nails spaced 8" o.c. in both directions with perimeter fasteners at least 3/8" and less than 5/8" from ends and edges. Drive nails and screws so that bottoms of heads are flush with panel surface to ensure firm panel contact with subfloor. Do not overdrive fasteners. Prefill joints with tile-setting mortar or adhesive and then immediately embed DUROCK tile backer tape and level joints.</p>
	3.2 Walls	<p>A Framing—Space wood and steel framing a maximum of 16" o.c. (24" o.c. for UL Design U459 or U415). The studs of freestanding furred walls must be secured to the exterior wall with wall furring brackets or laterally braced with horizontal studs or runners spaced 4' o.c. max. Laterally brace all steel-framed walls prior to the application of joint treatment.</p> <p>B Panel Application—After tub, shower pan or receptor is installed, place temporary 1/4" spacer strips around lip of fixture. Pre-cut board to required sizes and make necessary cutouts. Fit ends and edges closely but not forced together, leaving a 1/8" gap. Install board abutting top of spacer strip. Stagger end joints in successive courses. Fasten panels to framing with specified fasteners. Drive fasteners into field of panels first, working toward ends and edges. Hold panels in firm contact with framing while driving fasteners. Space fasteners maximum 8" o.c., with perimeter fasteners at least 3/8" and less than 5/8" from ends and edges. Drive nails and screws so that bottoms of heads are flush with panel surface to ensure firm panel contact with framing. Do not overdrive fasteners. Approved fasteners include: DUROCK tile backer screws for steel framing (or equivalent), 1-1/4" and 1-5/8" for 14- to 20-gauge steel framing; DUROCK tile backer screws for wood framing (or equivalent), 1-1/4", 1-5/8", and 2-1/4" for wood framing. Nails (1-1/2" hot-dipped galvanized roofing nails). In double-layer walls where cement boards are installed over base-layer gypsum boards, apply a vapor-permeable water barrier over gypsum boards.</p> <p>C Shaft Wall—Attach DUROCK cement board over base layer of gypsum panels with 1-5/8" DUROCK tile backer screws for steel framing at 8" o.c. to studs. Since studs are at 24" o.c., laminate cement board to base layer of gypsum panels with a 4" wide strip of construction adhesive between studs. Apply adhesive with a 1/4" square-notched trowel.</p> <p>D Exterior Walls—Attach DUROCK cement board with corrosion-resistant screws spaced a maximum of 8" o.c. over framing spaced a maximum of 16" o.c. Apply a weather-resistive barrier and flashing behind the panels as required. Follow the exterior finish manufacturer's recommendations for application over DUROCK cement board.</p>

DUROCK
Cement Board Systems

<p>3.3 Countertops</p>	<p>A Base—Install minimum 3/4" exterior-grade plywood base across wood cabinet supports spaced maximum 16" o.c. Position ends and edges over supports.</p> <p>B Membrane—Staple-attach DUROCK tile membrane, 15-lb. felt or 4-mil polyethylene film using 1/4" galvanized staples over plywood base.</p> <p>C Panel Application—Secure DUROCK cement board to plywood. Fasten to plywood with 1-1/4" DUROCK tile backer screws for wood framing or 1-1/2" hot-dipped galvanized roofing nails spaced 8" in both directions and around edges; fit ends and edges closely but not forced together, leaving a 1/8" gap.</p> <p>D Joint Finishing—Prefill joints with latex-fortified mortar or Type 1 organic adhesive; completely embed DUROCK tile backer tape; and level all joints and outside corners.</p>
<p>3.4 Ceilings</p>	<p>A Framing—Ceiling joists, furring channels or strips must be spaced max. 16" o.c. Framing must be capable of supporting the total ceiling system dead load, including insulation, ceramic tile, bonding materials and cement board, with deflection not exceeding L/360 of the span. When steel framing is used, min. 20 ga. is required.</p> <p>B Panel Application—Apply 1/2" DUROCK cement board to framing with long dimension across framing. Center end or edge joints on framing and stagger joints in adjacent rows. Fit ends and edges closely, but not forced together, leaving a 1/8" gap. Fasten boards to steel framing with 1-1/4" DUROCK tile backer screws for steel framing spaced 6" o.c. and to wood framing with 1-5/8" DUROCK tile backer screws for wood framing spaced 6" o.c. with perimeter fasteners at least 3/8" and less than 5/8" from ends and edges. If necessary, provide additional blocking to permit proper attachment. Edges or ends parallel to framing shall be continuously supported.</p>
<p>3.5 Joint Treatment Application</p>	<p>A For Tile and Thin Brick—Prefill all DUROCK cement board joints, and joints where DUROCK cement boards abut other panels or surfaces such as gypsum board, with tile-setting mortar or adhesive, and then immediately embed tape and level the joints.</p> <p>B For Dry Untiled Areas—For small areas where the DUROCK cement board will not be tiled, such as a board extending beyond the tiled area and abutting another surface, treat joints as follows. Seal DUROCK board with Type 1 ceramic tile adhesive. (Mix four parts adhesive with one part water.) Embed SHEETROCK® joint tape over joints and treat fasteners with SHEETROCK® DURABOND® setting-type joint compound (45 or 90) applied in conventional manner. Flat trowel SHEETROCK setting-type joint compound over board to cover fasteners and fill voids to a smooth surface. Finish joints with at least two coats SHEETROCK® ready-mixed joint compound. Do not apply ready-mixed or setting-type joint compound over unsealed board.</p>
<p>3.6 Interior Ceramic Tile Application</p>	<p>A Tile Application—Plan tile layout, then spread latex-modified thin-set mortar or Type 1 adhesive with trowel recommended by tile manufacturer held at 45° angle. Apply no more adhesive than can be covered in 20 to 30 minutes. Open time will vary according to temperature and humidity. NOTE: When applying over old ceramic tile, allow adhesive to set 10 to 15 minutes before applying new tile. Wall tiles may be set top down or bottom up. Press, do not slide, tiles and sheets of tile into adhesive. Maintain accurate joint alignment and spacing as tiles are positioned. Use wooden or rubber-faced beating block, tapped lightly with a mallet to level and ensure solid tile positioning. Check occasionally to ensure at least 95% adhesive transfer to back of tile. Avoid adhesive squeeze-up between tiles. It may be necessary to butter adhesive on backs of large pavers and quarry tile. NOTE: Contractors installing ceramic tile should always follow ANSI Specifications and TCNA Guidelines.</p> <p>B Drying Time—Do not walk on floors for at least 48 hours unless walking boards or plywood sheets are used. To finish job, wait 24 hours after tile has been installed for walls and countertops, 48 to 72 hours for floors, before grouting.</p> <p>C Grouting—Select, prepare and install grout in accordance with recommendations provided by grout manufacturers.</p>
<p>3.7 Exterior Applications</p>	<p>A Follow the exterior finish manufacturer's recommendations for finishes applied to DUROCK cement board.</p> <p>B It is recommended that a weather resistive barrier and flashing be installed behind DUROCK cement board in direct-applied finish applications to provide a means for draining any intruding moisture safely from the exterior of the building.</p> <p>C Follow the manufacturer's recommendation, design professional, or contract documents for proper sealants and flashings at openings such as windows and doors.</p>

Websites

usg.com/durock
usgdesignstudio.com

Technical Service

800 USG.4YOU
usg4you@usg.com

Samples/Literature

samplit@usg.com

Customer Service

800 621.9523

Metric Specifications

USG Corporation, through its operating subsidiaries, will provide metric conversions on its products and systems to help specifiers match metric design sizes. In addition, some products are available in metric dimensions from selected manufacturing plants. Refer to SA100 *Construction Selector* for additional information and a Table of Metric Equivalents.

Trademarks

The following trademarks used herein are owned by United States Gypsum or a related company: DUROCK, DIAMOND, DURABOND, FIBEROCK, FIRECODE, IMPERIAL, MOLD TOUGH, SHEETROCK, USG, USG in stylized letters. THERMAFIBER is a trademark of THERMAFIBER LLC.

Notice

We shall not be liable for incidental and consequential damages, directly or indirectly sustained, nor for any loss caused by application of these goods not in accordance with current printed instructions or for other than the intended use.

Our liability is expressly limited to replacement of defective goods. Any claim shall be deemed waived unless made in writing to us within thirty (30) days from date it was or reasonably should have been discovered.

Note

All products described here may not be available in all geographic markets. Consult your local sales office or representative for information.

Safety First!

Follow good safety and industrial hygiene practices during handling and installing all products and systems. Take necessary precautions and wear the appropriate personal protective equipment as needed. Read material safety data sheets and related literature on products before specification and/or installation.

