

Product and Systems Technology

Lathing and Plastering Specifications for Handball and Racquetball Courts

PM14

Description and Use

Handball and racquetball court surfaces are subjected to considerable impact and abuse which impose special performance requirements on the plasters used. Walls must be more rigid and surfaces must be extremely hard to resist ball impacts as high as 1500 psi.

A system developed by United States Gypsum Company to provide these characteristics uses STRUCTO-GAUGE® gauging plaster and Type S finish lime (or IMPERIAL® veneer finish) applied over a basecoat of STRUCTO-BASE® gypsum plaster to produce an unyielding, rock-hard surface. On the front wall, plaster is applied to either a furred insulated application and ROCKLATH® gypsum plaster base on exterior masonry or monolithic concrete, or direct to interior masonry or monolithic concrete walls, or to steel stud furring with ROCKLATH gypsum plaster base over which 3.4 lb. diamond mesh lath is supported on a grid of 1/4" pencil rods on 2'0" centers in each direction. On side and back walls, 3.4 lb. self-furring metal lath is used as the plaster base over concrete, masonry or ROCKLATH® plaster base on light-gauge steel studs or furring channels.

CAUTION: Damage may be caused to wall surface by direct impact with racquet.

Ceilings consist of ROCKLATH plaster base screw-attached to metal furring channels secured to a conventional furred or suspended ceiling grillage and plastered in the same manner as the walls.

For additional information on USG plasters, bases and accessories, see United States Gypsum Company technical folder SA920 or ask your local United States Gypsum representative.

Specifications

Good Design Practices

1. Design of the floor/wall juncture should provide sufficient relief to accommodate structural movement.
2. The plaster basecoat must be leveled to a true plane to minimize thickness variations in the finish coat. The finish coat should be as thin and tight as possible, not over 1/16", and troweled completely to a smooth, dense surface.
3. Finish coat decoration should be delayed 12 months to permit surface to age properly for maximum hardness.
4. Forced ventilation is required to complete drying of both base and finish coats.
5. Exterior walls are constructed to provide both a vapor retarder and furring to separate the interior system from the masonry surface.
6. Select steel studs based on maximum deflection of L/360 based on stud properties only, under a uniform load of 10 psf, studs at max. 16" o.c.

Part 1: General

1.1 Scope *Specify to meet project requirements.*

1.2 Qualifications All materials, unless otherwise indicated, shall be manufactured by United States Gypsum Company, and shall be installed in accordance with its current printed directions.

1.3 Delivery and Storage of Materials All packaged materials shall be delivered in their original unopened containers and stored in an enclosed shelter providing protection from damage and exposure to the elements. Damaged or deteriorated materials shall be removed from the premises. Masonry units shall be protected from moisture at the jobsite.

1.4 Environmental Conditions

- a. In cold weather, the temperature of the building shall be maintained in the uniform range above 55 °F for an adequate period prior to and during application of plaster, and until the plaster is dry. The heat shall be well distributed to all areas with protective screens used to deflect concentrated heat from plaster areas near source.
- b. Ventilation shall be provided to properly dry plaster during and subsequent to its application. Provision must be made to mechanically remove moisture-laden air, with ventilation maintained until plaster has set and dried.

1.5 Protection Proper protection shall be provided during plastering for finished door and window frame and other designated areas which do not receive a plaster finish.

Part 2: Products

2.1 Materials

- a. **Masonry Plaster Base:** (clay tile) (concrete block) (monolithic concrete) ()" thick, properly cured or kiln-dried
- b. **Portland Cement:** Type I, II, or III, complying with ASTM C150.
- c. **Plaster Base:** Regular ROCKLATH gypsum plaster base, 3/8" thick, (3.4 lb. self-furring diamond mesh lath).
- d. **Basecoat Plaster:** STRUCTO-BASE gypsum plaster.
- e. **Aggregate:** Sand meeting ASTM C35 requirement for plaster, ASTM C144 for mortar.
- f. **Water:** Potable and not containing impurities that affect the setting of gypsum.
- g. **Lime:**
 - 1. Plaster—Type S finish
 - 2. Mortar—Regular or air-entraining mason's lime, Type S.
- h. **Gauging Plaster:** STRUCTO-GAUGE.
- i. **Finish Plaster:** IMPERIAL veneer finish.
- j. **Reinforcing Bars:** 1/4" round, steel pencil rods.
- k. **Reinforcing Bar Attachment Brackets:** wall furring brackets.
- l. **Lathing Channel:** Cold-rolled channels, (3/4) (1-1/2) (2)".
- m. **Furring:** 7/8" metal furring channel; Z-furring channel (1) (2) (3)".
- n. **Lath Attachment Clip:** BRIDJOINT field clip B-1.
- o. **Casing Bead:** #66 casing bead, expanded flange.
- p. **Tie Wire:** (16) (18) ga.
- q. **Fasteners:** Steel screws, Climaseal-coated, 1" TYPE S, 1" TYPE S-12, 1/2" TYPE S-12 low profile head.
- r. **Insulation:** Polystyrene (1) (2) (3)".
- s. **Vapor Retarder:** 4 mil. polyethylene.
- t. **Steel Studs:** Min. 20 ga.
- u. **Runner Track:** Min. 20 ga.
- v. **USG Plaster Bonder**

2.2 Mixes

- a. Mortar—Portland cement-lime mortar—mix in a proportion of 1 bag (94 lb.) portland cement to 2 bags (100 lb.) mason's lime to 9 cu. ft. of sand.
- b. Basecoat shall be mixed in the following proportions. For scratch coat—over ROCKLATH, 2:1; over block, 3:1. For brown coat—over ROCKLATH, 2-1/2:1; over monolithic concrete, 21/2:1; over block, 3:1.
- c. Finish plaster shall be mixed in dry-weight proportions of 1:1 parts Type S lime to STRUCTO-GAUGE gauging plaster.
- d. Finish plaster (option): IMPERIAL veneer finish shall be mixed with water only per manufacturer's directions.

Part 3: Execution

3.1 Masonry Partition Backup

- a. Erect masonry plaster base backup of clay tile, concrete block or monolithic poured concrete. Lay up masonry with a full mortar bed, full end joint and in running bond. Cut mortar joints flush with surface. Reinforce horizontal joints at every third course.
- b. Erect concrete block or clay tile using portland cement-lime mortar.
- c. Coat clay tile or monolithic concrete interior wall surfaces with USG plaster bonder in a continuous film according to product directions. Remove all dirt, grease, wax, oil, efflorescence and parting compounds from monolithic concrete surfaces before applying a continuous application of USG plaster bonder.

3.2 Steel Stud Interior Dividing Walls

- a. Fasten top and bottom runner tracks to structure with power-activated fasteners spaced 12" o.c. Set studs in runner tracks and space no more than 16" o.c. Fasten to bottom runners with 1/2" TYPE S-12 low profile head screws, with one screw in each flange. Studs shall be cut 3/8" short to allow for deflection.
- b. Fasten 3/8" thick ROCKLATH plaster base to studs with 1" TYPE S-12 screws, four per stud.

3.3 Exterior Masonry Walls

- a. Exterior building walls shall be waterproofed before installation of plaster system. Interior of exterior walls must be furred.
- b. Erect insulation vertically and hold in place with Z-furring channels spaced 16" o.c. Install channels over polyethylene vapor retarder; attach narrow flanges of channels to wall with concrete stub nails or power-driven fasteners spaced 24" o.c.
- c. Fasten 3/8" thick ROCKLATH plaster base to Z-furring channels with 1" TYPE S screws, three per stud. Use BRIDJOINT clips at end joints between channels.

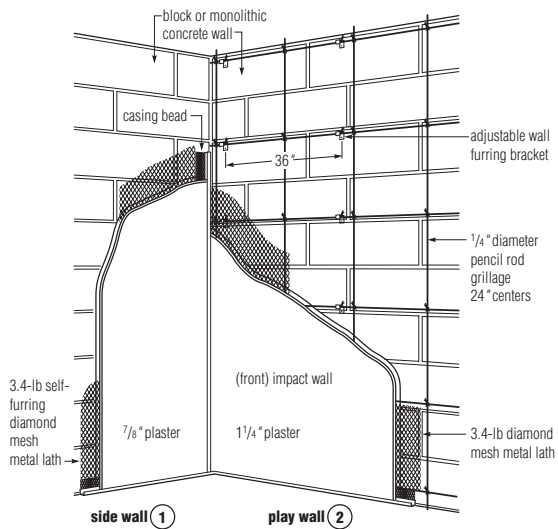

Interior uninsulated assemblies

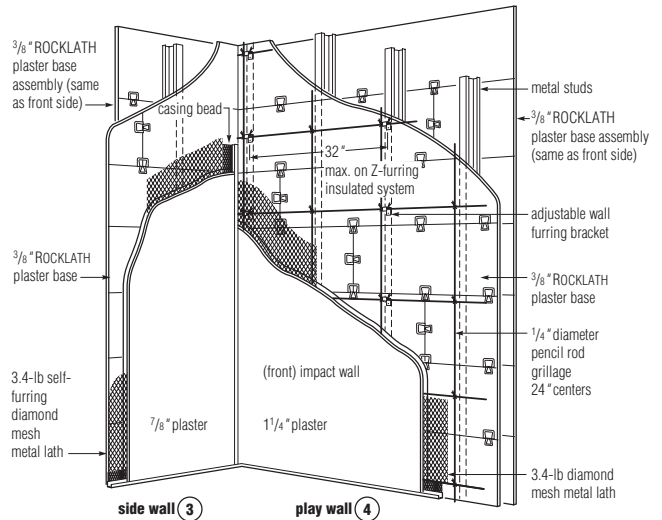

Interior uninsulated assemblies

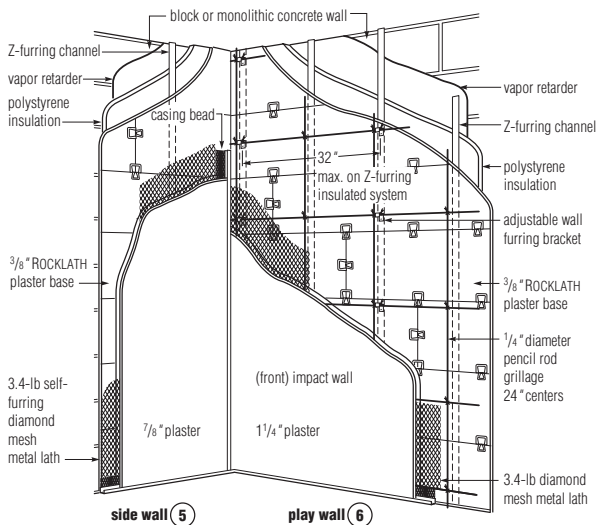

Exterior insulated assemblies

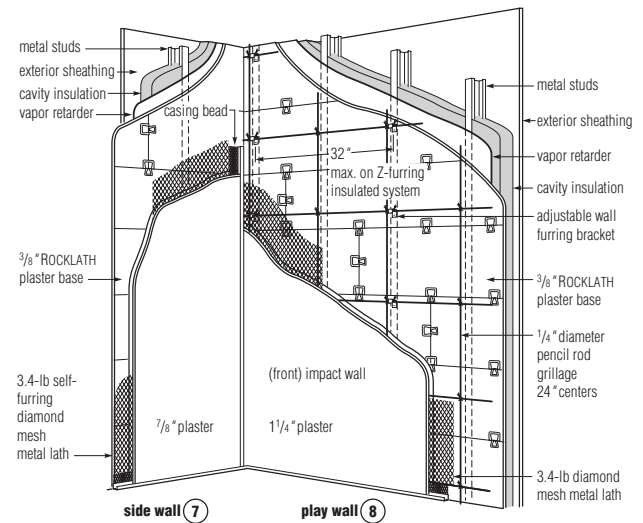

Exterior insulated assemblies

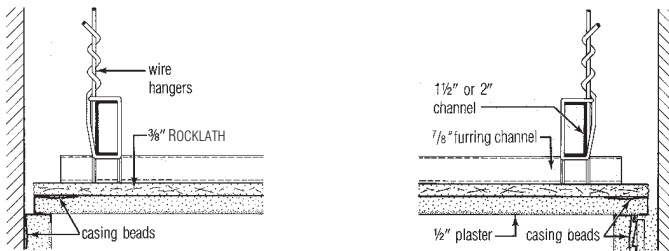

Wall-ceiling intersections
(uninsulated or insulated assemblies)

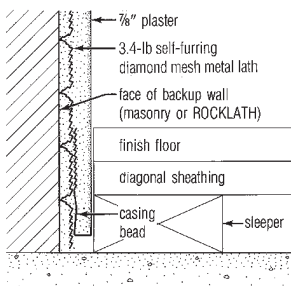

base at end and sidewalls

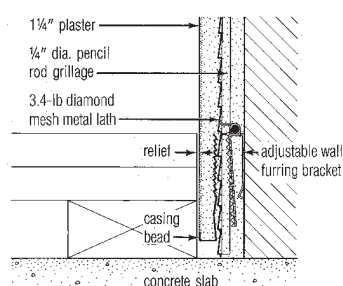

base at impact wall

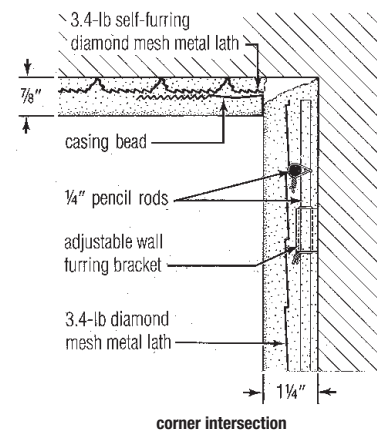

corner intersection

3.4 Grounds	Set ground by means of mechanical beads or screed to provide minimum 1-1/4" thickness on front wall, 7/8" on side and back walls, 1/2" on ceilings.
3.5 Lathing	<p>a. Front Wall—Provide reinforcing grid of 1/4" pencil rods spaced 24" o.c. each way, supported by adjustable wall furring brackets spaced 36" o.c. on masonry or concrete, and 32" on furred insulated and steel stud applications. Securely wire-tie 3.4 lb. diamond mesh lath to the grid, held 7/8" away from face of masonry or ROCKLATH plaster base.</p> <p>b. Side and Back Walls—Lath with 3.4 lb. self-furring metal lath directly over concrete or masonry. Steel frame partition shall be lathed with ROCKLATH plaster base and 3.4 lb. self-furring metal lath.</p> <p>c. Ceiling—Fasten 3/8" thick ROCKLATH plaster base to furring channel with three 1" TYPE S screws per channel. Add metal reinforcement at all corners of recessed light fixture openings or grilles. Staple 12" x 24" metal lath reinforcement diagonally across corner openings.</p> <p>d. Internal Angles and Wall/Floor Juncture—Attach #66 casing bead to face of metal lath and coat bead with USG plaster bonder.</p>
3.6 Grouting	Grout steel door and window frames in solid plaster before applying metal lath.
3.7 Plaster Basecoat Application	Mix basecoat plaster in a mechanical mixer to a uniform consistency following manufacturer's directions. Apply scratch coat, using sufficient pressure to force plaster through the metal reinforcement, and bond it to the masonry or ROCKLATH plaster base without leaving voids. After scratch coat has set and partially dried, apply brown coat and screed to a true, level plane. Leave surface sufficiently rough to mechanically key finish coat.
3.8 Finish Plaster Application	Apply finish in as thin an application as possible to partially dry basecoat. Final thickness shall not exceed 1/16". Hand-finish troweling is required to smooth and densify surface. When IMPERIAL veneer finish is used, take care in joinings and with base application to ensure a smooth finished surface.
3.9 Completion	At completion of the finish plaster work, clean all plaster from exposed metal, leaving work ready for decoration by others at a later time. Remove all plaster rubbish, excess material, scaffolding, tools and other equipment from the building, leaving floors broom clean.

Trademarks

The following trademarks used herein are owned by United States Gypsum Company: IMPERIAL, ROCKLATH, STRUCTO-BASE, STRUCTO-GAUGE, BRIDJOINT, USG, USG in stylized letters, Climaseal, Type S and Type S-12 are trademarks of ITW Buildex.

Note

Products described here may not be available in all geographic markets. Consult your U.S. Gypsum Company sales office or representative for information.

Notice

We shall not be liable for incidental and consequential damages, directly or indirectly sustained, nor for any loss caused by application of these goods not in accordance with current printed instructions or for other than the intended use. Our liability is expressly limited to replacement of defective goods. Any claim shall be deemed waived unless made in writing to us within thirty (30) days from date it was or reasonably should have been discovered.

Safety First!

Follow good safety and industrial hygiene practices during handling and installing products and systems. Take necessary precautions and wear the appropriate personal protective equipment as needed. Read material safety data sheets and related literature on products before specification and/or installation.

