Logix™ Systems

Code Requirements¹

The International Building Code (IBC) defines the seismic requirements for suspended ceiling systems. Generally, these requirements must be defined in the project drawings. However, there are exceptions and the actual construction of LOGIX suspended ceiling system in a seismic design category can meet code requirements in different ways. This technical guide provides drawings, details, and specification information for the use of USG® LOGIX™ in a seismic application.

With LOGIX™, you can design ceilings that meet building requirements without being constrained by the limits of traditional acoustical ceilings. LOGIX transforms visual distractions such as lighting, air vents and other utilities into dramatic design elements by concentrating these fixtures on narrow bands that run the length of a ceiling. This allows for open ceilings that are uncluttered by ceiling utilities.

A wide selection of acoustical and specialty panels as well as corresponding suspension system components and accessories are available to enhance and customize your design. Plus, with a wide selection of Logix partners, you can be assured that ceiling utilities will complement your design and integrate seamlessly into the ceiling.

This guide is a comprehensive resource for LOGIX Integrated Ceiling Systems in a seismic application. There are generally no unique seismic requirements for LOGIX Systems, however, due to some of the non-traditional module sizes, special attention is required to ensure all seismic requirements are satisfied. USG teamed with the Pacific Earthquake Engineering Research Center (PEER) University of California, Berkeley to conduct full-scale dynamic seismic shake-table testing to evaluate and qualify the seismic performance of LOGIX Integrated Ceiling Systems. This testing proved that LOGIX Integrated Ceiling Systems are approved for use and provide a code-compliant solution meeting International Building Code (IBC) requirements, including installations in all seismic design categories.

USG Logix™ Integrated Ceiling System



¹ See last page for Seismic Code Reference Standards

Logix Integrated Ceiling Systems

Seismic Construction

In addition to the current seismic code requirements¹ the applications in the following section shall apply to Logix systems concerning perimeter treatment, ashlar connections, and planks and large size panels².

- (A) ✕ 12-gauge perimeter hanger wire
- (B) T ACM7 seismic clip
- (C) † Ashlar treatment
- (D) - - - stabilizer bar

Seismic Construction Application Components

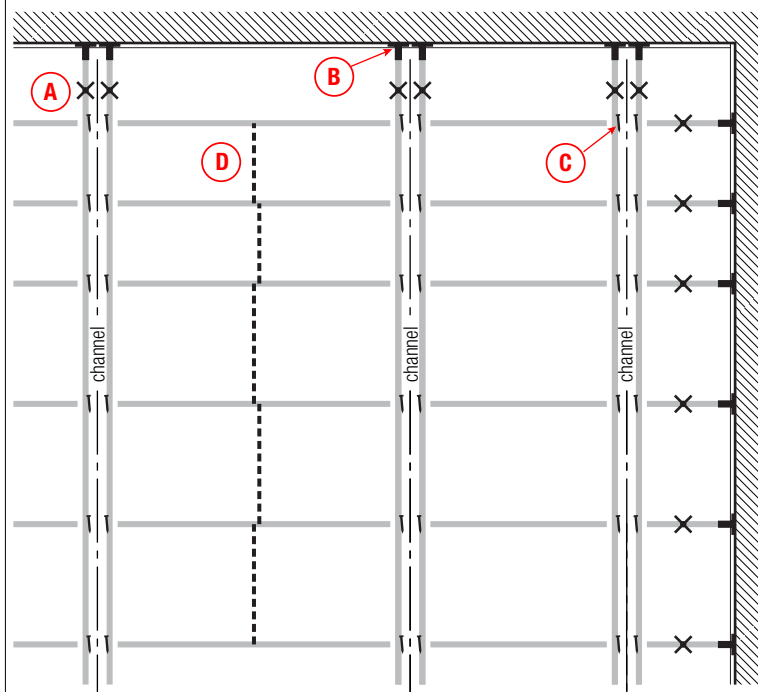

¹Please refer to seismicceilings.com for current seismic requirements.

²Please refer to IS265 for complete information about the various layouts and sizes available.

Note:

The performance of Logix Integrated Ceiling Systems is based on the specific combination of superior components including our quick release cross tee clip, and the design and installation methods shown. Suspension system components from other manufacturers were not evaluated, and their use or any mixed use is not recommended or covered by this guide.

Logix Integrated Ceiling Systems

Perimeter Treatment

ACM7 Seismic Clip¹

Seismic Design Category C

USG ACM7 seismic clip shall be used to secure the tee ends to the wall molding allowing for the minimum clearance of 3/8" (10 mm). Minimum 7/8" (22 mm) perimeter supporting closure angle (wall molding) shall be utilized.

Floating sides

Profile

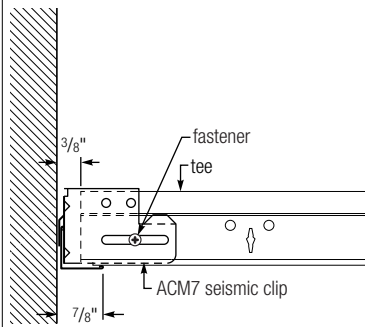

Isometric

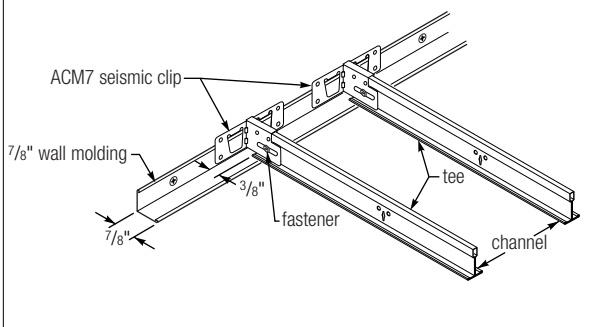

Fixed Sides

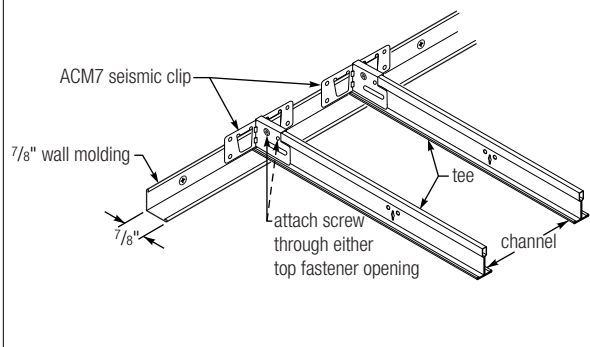
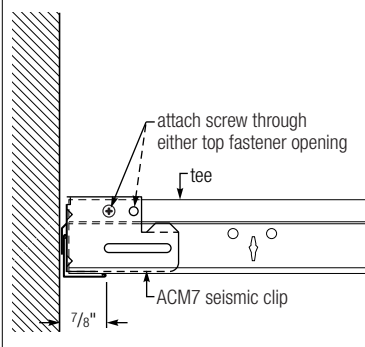

¹ Please refer to AC3269 for more information about the USG ACM7 seismic clip.

Note: USG has performed dynamic shake-table testing on assemblies utilizing the ACM7 seismic clip with fasteners and without fasteners relying on the friction fit mechanisms of the clip. Both methods passed and are approved for use.

Logix Integrated Ceiling Systems

Perimeter Treatment

ACM7 Seismic Clip¹

Seismic Design Category D, E and F

USG ACM7 seismic clip shall be used to secure the tee ends to the wall molding allowing for the minimum clearance of 3/4" (19 mm) on two, adjacent sides. Minimum 7/8" (22 mm) perimeter supporting closure angle (wall molding) shall be utilized.

Floating sides

Profile

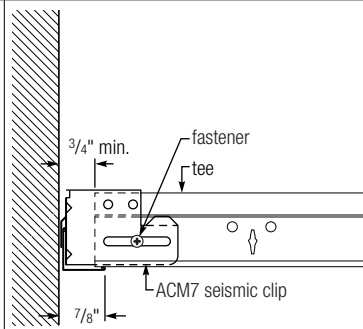

Isometric

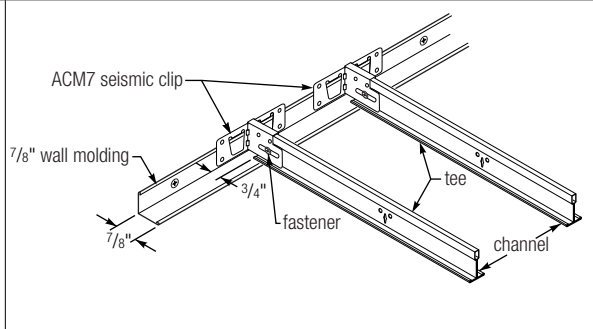

Fixed Sides

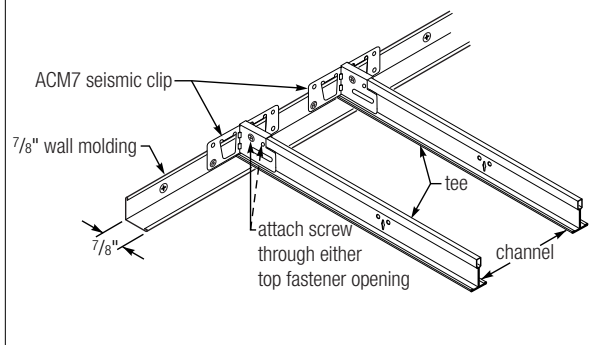
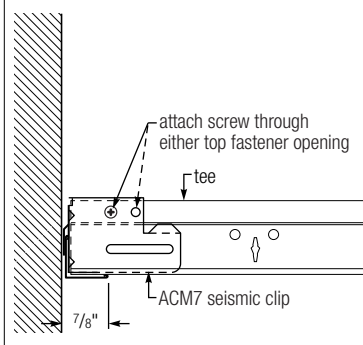

¹ Please refer to AC3269 for more information about the USG ACM7 seismic clip.

Note: USG has performed dynamic shake-table testing on assemblies utilizing the ACM7 seismic clip with fasteners and without fasteners relying on the friction fit mechanisms of the clip. Both methods passed and are approved for use.

Logix Integrated Ceiling Systems

Perimeter Treatment

Perimeter Hanger Wires

Seismic Design Category D, E, and F

Perimeter tees must be supported by vertical hanger wires not more than 8" (203 mm) from the wall.

	Profile	Isometric
Floating sides		
Fixed Sides		

¹ Please refer to AC3269 for more information about the USG ACM7 seismic clip.

Note: USG has performed dynamic shake-table testing on assemblies utilizing the ACM7 seismic clip with fasteners and without fasteners relying on the friction fit mechanisms of the clip. Both methods passed and are approved for use.

Logix Integrated Ceiling Systems

Ashlar Connections

Guidelines

- USG DH3 3-Way Connector with a fastener connection to the main tee and a fastener connection to the cross tee is acceptable for use in ashlar installations in seismic design categories C, D, E and F.
- 1-1/2 in. masonry nail inserted through a non-opposing cross tee clip is acceptable for use in ashlar installations in seismic design categories C, D, E and F.
- Ring nail inserted through a non-opposing cross tee clip is acceptable for use in ashlar installations in seismic design category C.
- Pop rivet inserted through a non-opposing cross tee clip is acceptable for use in ashlar installations in seismic design category C.
- In conditions where a non-opposing cross tee clip must be cut to accommodate a light fixture or other building element, the USG DH3 3-Way Connector with a fastener connection to the main tee and a fastener connection to the cross tee is acceptable for use in ashlar installations in seismic design categories C, D, E and F.
- Hanger wire inserted through a non opposing cross tee clip is not recommended for use in ashlar installations in seismic design categories C, D, E and F.
- Bending or folding a non-opposing cross tee clip is not recommended.

Assembly From Above

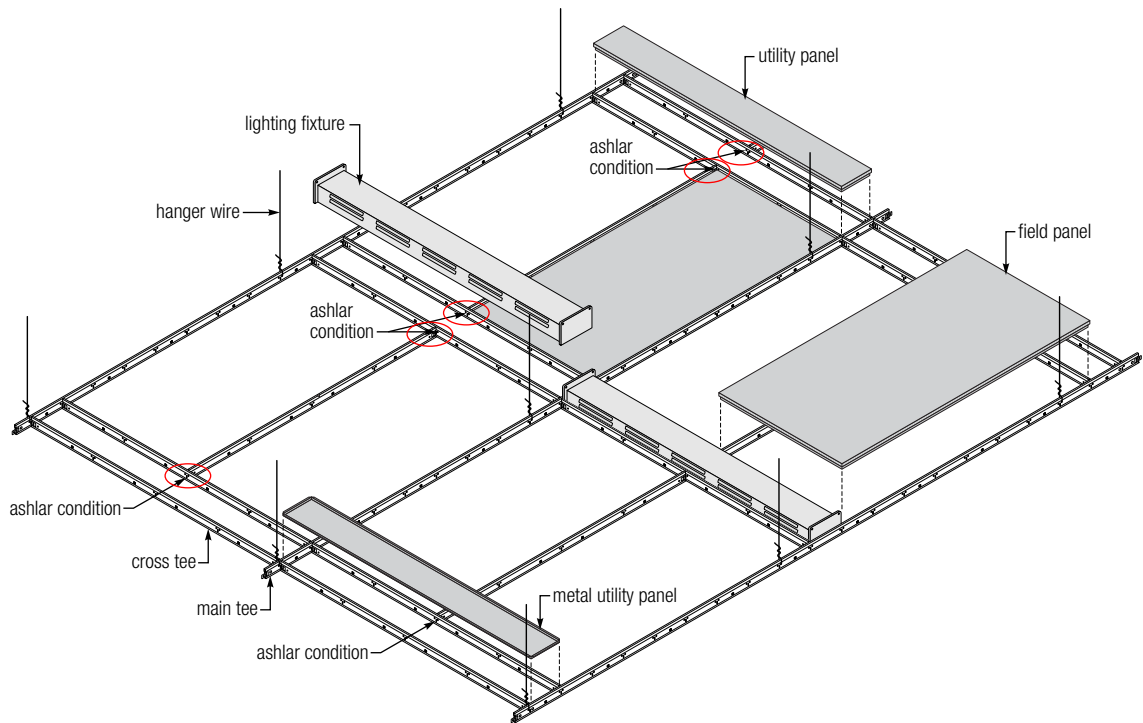

Logix Integrated Ceiling Systems

Ashlar Connections

Seismic Design Categories C, D, E and F

USG DH3 3-Way Connector with a fastener connection to the main tee *and* a fastener connection to the cross tee.

1-1/2 in. masonry nail inserted through a non-opposing cross tee clip

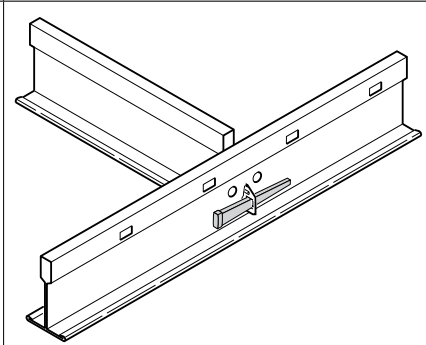
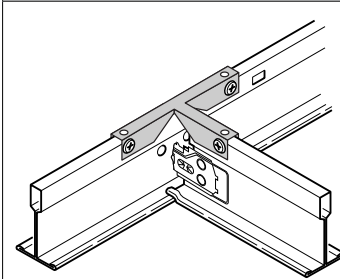

Seismic Design Category C

Ring nail inserted through a non-opposing cross tee clip

Pop rivet inserted through a non-opposing cross tee clip

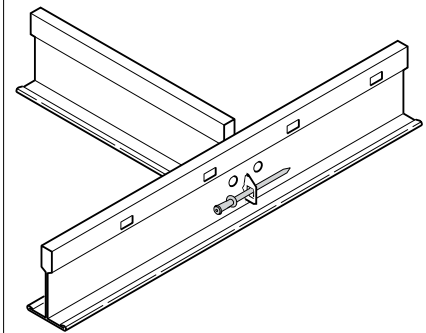
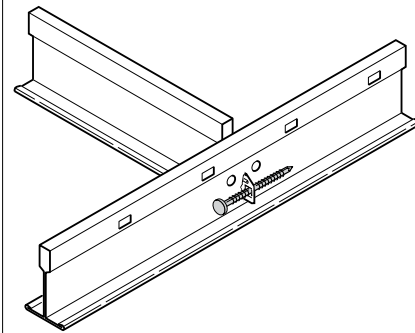

Performance Data	Minimum Connection Values in Pounds	Seismic Design Category D, E, and F		Seismic Design Category C
		Ashlar Condition Connection Type	Tension	Tension
		USG DH3 3-Way Connector	200	200
		1-1/2 in. Masonry Nail	236	236
		Ring Nail	N/A	100
		Pop Rivet	N/A	100

Note: The performance of Down suspension systems is based on the specific combination of superior components including our quick release cross tee clip, and the design and installation methods shown. Suspension system components from other manufacturers were not evaluated, and their use or any mixed use is not recommended or covered by this guide.

Logix Integrated Ceiling Systems

Ashlar Conditions

Construction

Seismic Design Category D, E and F

Channel Detail Masonry Nail

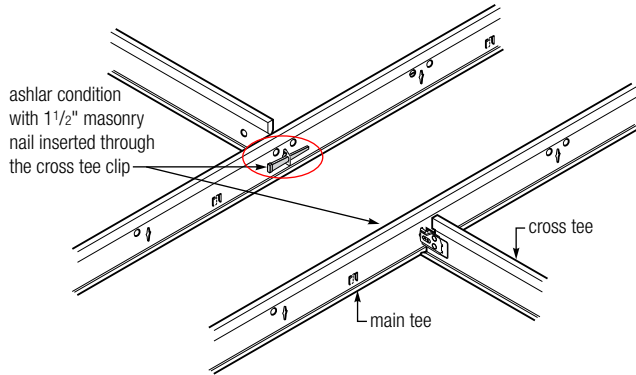

Channel Detail DH3 3-Way Connector

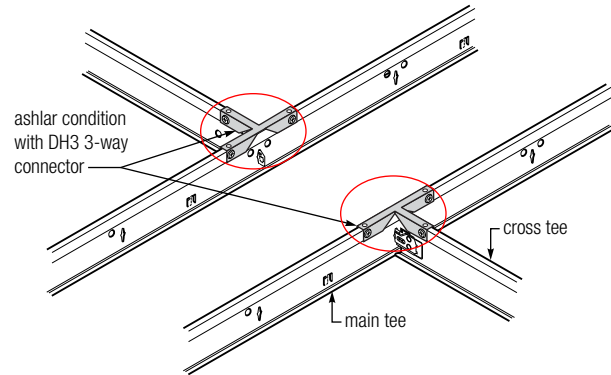

Seismic Design Category C

Channel Detail Ring Nail

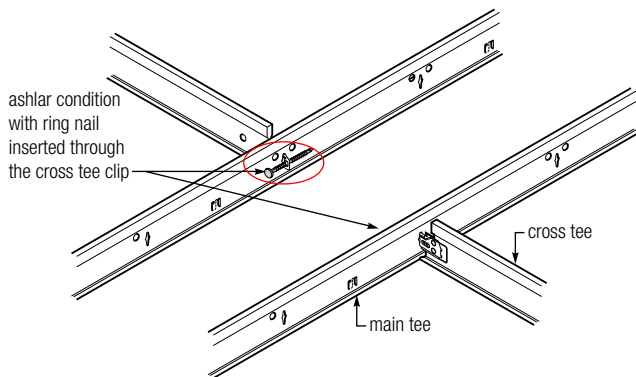

Channel Detail Ring Nail

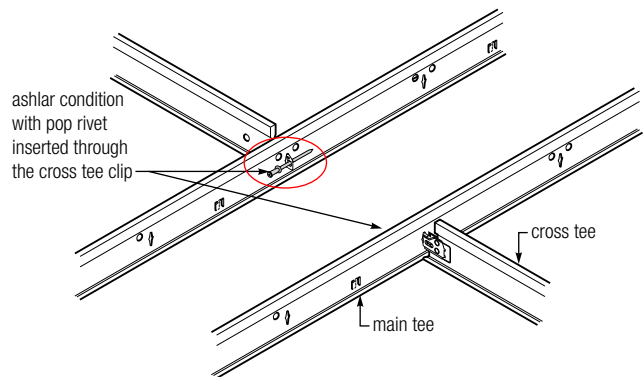

Logix Integrated Ceiling Systems

Plank and Large Sized Panels

Stabilizer Bars

The USG DONN® Brand Stabilizer Bar provides rigid support for a ceiling suspension system in seismic applications. Specially notched compression bars attach to the top bulb of main tees and cross tees to provide strength. The DONN Brand Stabilizer Bar is a unique, factory engineered solution that meets the requirements for seismic ceiling installations. The variety of factory-notched stabilizer bars with locking tabs saves installation time for overall cost savings. A stabilizer bar is required for all module sizes greater than 60".

Note: For more information about stabilizer bars please refer to SC2540.

Logix Basic

Assembly from above

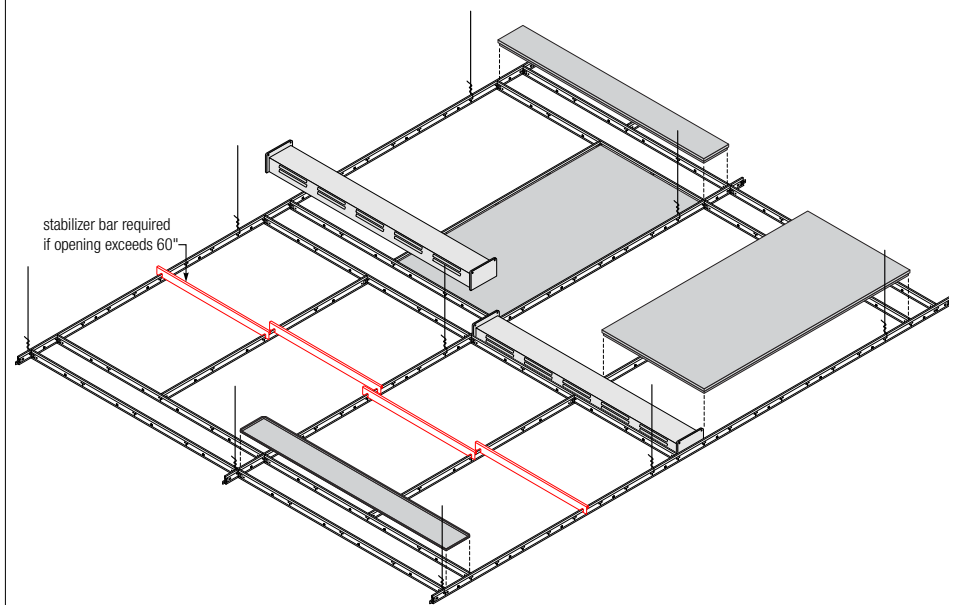

Logix Linear

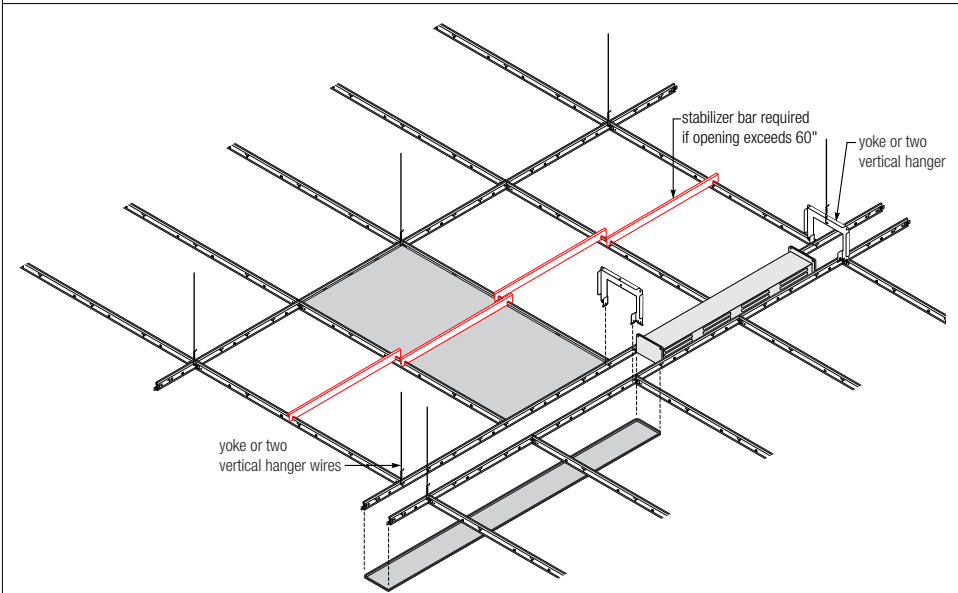

Seismic Code Reference Standards

Installation Guidelines for Suspended Ceilings				
International Building Code (IBC)	2003 IBC ↓	2006 IBC ↓	2009 IBC ↓	2012 IBC ↓
American Society of Civil Engineers (ASCE)	ASCE7-02 ↓	ASCE7-05 ↓	ASCE7-05 ↓	ASCE7-10 ↓
Ceilings Interior Systems Construction Association (CISCA) or ASTM International (ASTM)	CISCA Zones 0-2 CISCA Zones 3-4	CISCA Zones 0-2 CISCA Zones 3-4	CISCA Zones 0-2 CISCA Zones 3-4	ASTM E580

International Building Code (IBC) defines Seismic Design Categories A, B, C, D, E, and F.
www.iccsafe.org

ASCE/SEI 7 Minimum Design Loads for Buildings and Other Structures

American Society of Civil Engineers/Structural Engineer Institute (ASCE/SEI)
www.asce.org

Guidelines for Seismic Restraint for Direct-hung Suspended Ceiling Assemblies (Zones 3-4) Recommendations for Direct-hung Acoustical Tile and Lay-in Panel Ceilings (Zones 0-2)

CISCA Ceilings & Interior Systems Construction Association (CISCA)
www.cisca.org

ASTM International E580/E580M Standard Practice for Installation of Ceiling Suspension Systems for Acoustical Tile and Lay-in Panels in Areas Subject to Earthquake Ground Motions.

ASTM International (formerly American Society for Testing and Materials)
www.astm.org

Further References

USG Seismic Ceiling Resource Center

Seismic Technical Guides
www.seismicceilings.com

Product Information

See usg.com for the most up-to-date product information.

Installation

Must be installed in compliance with ASTM C636, ASTM E580, CISCA, and standard industry practices.

Code Compliance

The information presented is correct to the best of our knowledge at the date of issuance. Because codes continue to evolve, check with a local official prior to designing and installing a ceiling system. Other restrictions and exemptions may apply. This is only intended as a quick reference.

Purpose

This seismic technical guide (STG) is intended as a resource for design professionals, to promote more uniform criteria for plan review and jobsite inspection of projects. This STG indicates an acceptable method for achieving compliance with applicable codes and regulations, although other methods proposed by design professionals may be considered and adopted.

ICC Evaluation Service, Inc., Report Compliance

Suspension systems manufactured by USG Interiors, Inc., have been reviewed and are approved by listing in ICC-ES Evaluation Report 1222. Evaluation Reports are subject to reexamination, revision and possible cancellation. Please refer to usg.com for current reports.

L.A. Research Report Compliance

Down brand suspension systems manufactured by USG Interiors, Inc., have been reviewed and are approved by listing in the following L.A. Research Report number: 25764.

Notice

We shall not be liable for incidental and consequential damages, directly or indirectly sustained, nor for any loss caused by application of these goods not in accordance with current printed instructions or for other than the intended use. Our liability is expressly limited to replacement of defective goods. Any claim shall be deemed waived unless made in writing to us within thirty (30) days from date it was or reasonably should have been discovered.

Safety First!

Follow good safety/industrial hygiene practices during installation. Wear appropriate personal protective equipment. Read MSDS and literature before specification and installation.

