

# USG TRUE® WOOD LINEAR PLANKS

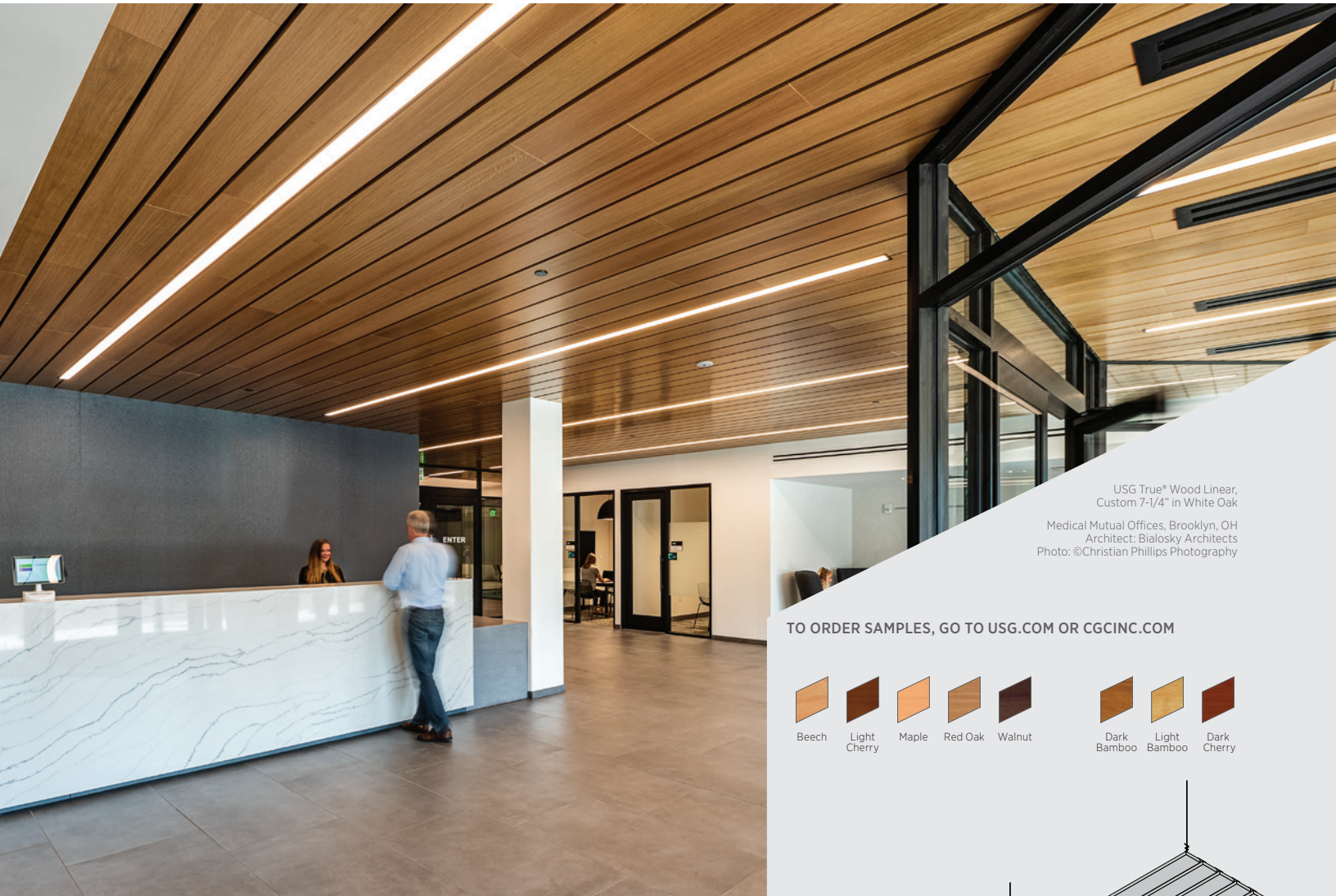

USG True® Wood Linear,  
Custom 7-1/4" in White Oak

Medical Mutual Offices, Brooklyn, OH  
Architect: Bialosky Architects  
Photo: ©Christian Phillips Photography

TO ORDER SAMPLES, GO TO [USG.COM](http://USG.COM) OR [CGCINC.COM](http://CGCINC.COM)

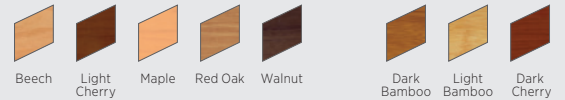

## FEATURES AND BENEFITS

- The elegance, warmth and majesty of true wood.
- Natural wood veneers.
- Linear plank sizes: 4 1/2" x 8' (3 3/4" actual dim.), 6" x 8' (5 1/4" actual dim.).
- Acoustical with 3/4" reveal between panels.
- FSC® certified.
- Class A fire rating.

## APPLICATIONS

- Interior Applications
- Pods, Islands, and Clouds
- Wall to Wall Ceilings
- Wall Applications
- Sloped Ceilings
- Curved Ceilings
- New Construction or Renovation
- Concealed Grid

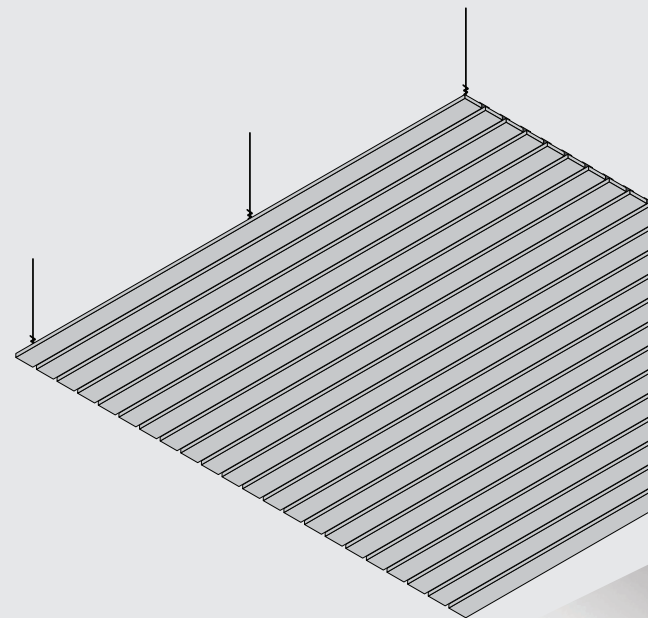

# USG TRUE® WOOD LINEAR PLANKS

**ORDER SAMPLES/LITERATURE**  
 USG: usg.com or samplitt@usg.com  
 CGC: contact Sales Representative

**TECHNICAL SERVICES**  
 800.USG.4YOU (874-4968)

**FOR MOST UP-TO-DATE TECHNICAL INFORMATION AND LEED REPORT TOOL**  
 usgdesignstudio.com  
 cgcdesignstudio.com  
 usg.ecomedes.com



## USG TRUE® WOOD LINEAR PLANKS

Linear Plank Size	Fire Rating	Grid Options	NRC	CAC
4-1/2" Module, 3-3/4" x 8' Plank with 3/4" black felt reveal	Class A	DWSS	0.40	—
6" Module, 5-1/4" x 8' Plank with 3/4" black felt reveal	Class A	DWSS	0.35	—

Linear Planks are screw-attached to heavy duty DWSS drywall grid. They have a black fabric backing that overlaps panel-to-panel to create a clean black look in the reveal.

## TRIM OPTIONS

4" Nominal (3-3/4"x8')

6" Nominal (5-1/4"x8')

## GRID PROFILE OPTIONS

### USG DRYWALL SUSPENSION SYSTEM

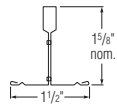

## ASSEMBLY

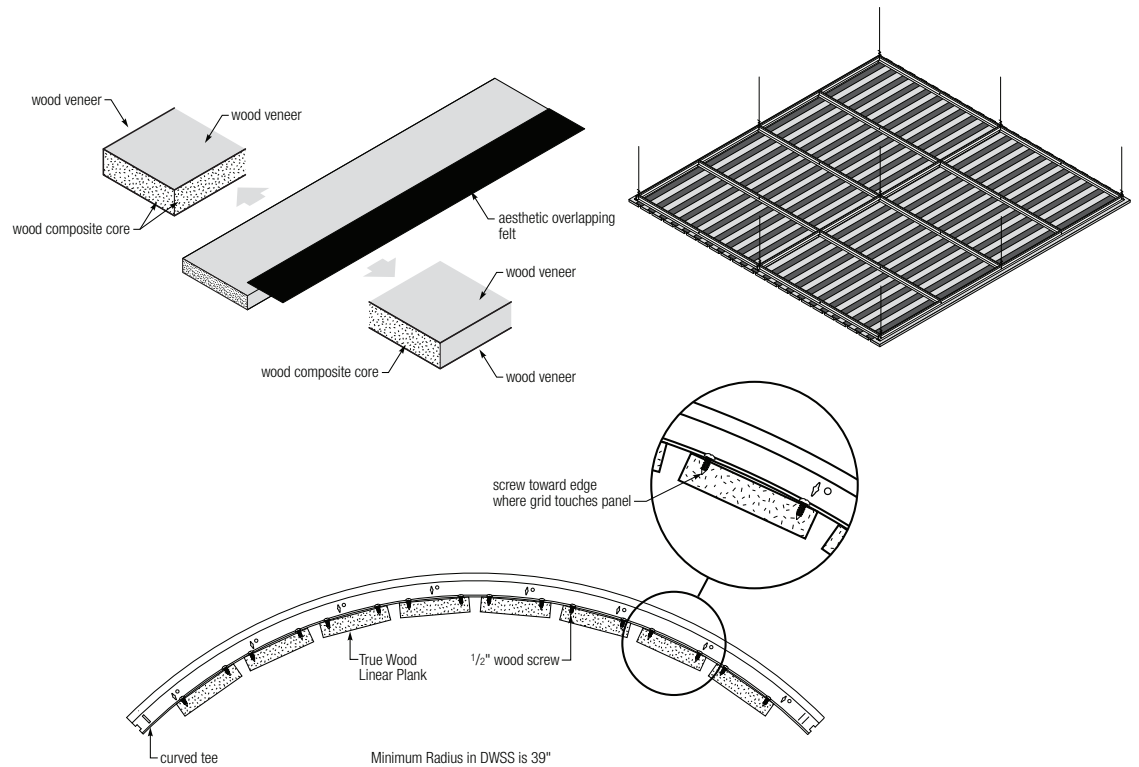

## PHYSICAL DATA

### High Recycled Content

USG classifies High Recycled Content as greater than 50%. Total recycled content is based on product composition of pre-consumer (post-industrial) and post-consumer recycled content per FTC guidelines.

### Additional Documents and Resources

Data Sheet: IC5409  
 Finishes Sheet: IC5409  
 Installation Guide: IC561  
 Warranty: SC2102  
 Handling Guide: IC5449

### Online Tools

usgdesignstudio.com, cgcdesignstudio.com or usg.ecomedes.com

### Fire Classification

ASTM E84 and CAN/ULC S102 surface-burning characteristics Class A  
 Flame spread: 25 or less  
 Smoke developed: 50 or less

### ASTM E1264 Classification

Composite—Class A Fire Performance ASHRAE Standard 62.1, 2013

### Weight

3 lb./sq. ft.

### Material

No added urea-formaldehyde core, with face cut veneers.

### Notes

- Color Disclaimer: Printed and/or online color swatches are only reproductions of actual standards and will vary in appearance due to differences in monitor and printer output.
- Wood Disclaimer: Wood is a natural grain product with variations in grain, texture and color often ranging from light to dark, thereby affecting the surface look. Product finishes are spray-applied stain or sealer coats.
- These representations should not be used to finalize color selection(s).
- Building environmental conditions should be maintained in accordance with ASHRAE Standard 62.1, 2013.
- Refer to *CISCA Wood Ceilings Technical Guidelines* for best practices on installing wood ceilings.

### Notice

The information in this document is subject to change without notice. CGC Inc. or USG Corp. assumes no responsibility for any errors that may inadvertently appear in this document.

### IC5409/rev. 7-24

© 2024 USG Corporation and/or its affiliates. All rights reserved. Printed in U.S.A.

Manufactured by USG Interiors, LLC  
 550 West Adams Street  
 Chicago, IL 60661

The trademarks USG, CGC, TRUE, IT'S YOUR WORLD, BUILD IT., the USG/CGC logo, the design elements and colors, and related marks are trademarks of USG Corporation or its affiliates.

Safety First! Follow good safety/industrial hygiene practices during installation. Wear appropriate personal protective equipment. Read SDS and literature before specification and installation.

